

De Vonk

Periodical of  E.T.S.V. Scintilla



BOARD 85

Bachelor Assignment

HTTPS Intrusion Detection

Main Article

Hybrid NanoElectronics

Year 33 | Edition 1 | December 2014



WE TURN YOUR IDEAS INTO TOMORROW'S PRODUCTS



APPLIED MICRO ELECTRONICS

AME is a fast growing organization developing and manufacturing high quality products with electronics. Our goal is to create innovative products for our customers that exceed market expectations by making use of state-of-the-art development facilities and a highly automated manufacturing environment. Driven by technology, we strive for the best solution combining the disciplines of applied physics, electrical, mechanical, software and industrial engineering.



OUR OFFER

We offer you a challenging career full of opportunities for personal and professional growth.



JOIN OUR TEAM OF EXPERTS

Driven to exceed expectations and to excel in creating innovative solutions, our team of experts is continuously looking for future best-in-class colleagues within the technological disciplines of applied physics, electrical, mechanical, software and industrial engineering.



CAREER POSSIBILITIES

If you are interested in working with a talented, ambitious and experienced team of professionals using the best tools available and would like to work in a fast growing organization full of career opportunities then you are most welcome to apply for a job or take a look at our opportunities by visiting our website.



INTERNSHIP OPENINGS

AME is the ideal work environment to develop hands-on experience while completing your studies. You will be involved in challenging real-world projects and work with experts from a multitude of technological disciplines. We invite you to get in touch with us to discuss any internship openings.

Halfway there

Author: Mickey Derks

Dear members, even though this is the first presidential note I wrote, when you read this, almost half the educational year has already passed. For all our first year members, this means that you should be well on the way of surviving the first year of this great study and the BSA, and for me, it means I will probably survive my year as a board member as well. Does this year seem to fly by as fast for you as it seems for me?

After a general meeting that seemed to go suspiciously smooth, we were charged as the 85th board of this beautiful association. I hope that the second one, in which the budget for 2015 and our long term policy from 2015 until 2019 should have been discussed, went just as smoothly. Now, after a few months filled with board tasks (planning and attending meetings, administrative work, doing the dishes, and other stuff required to keep Scintilla running smoothly) during work hours and other entertaining activities during the rest of the day (of course, attending all the courses, lunch lectures, drinks and more activities organized by our committees, but also attending constitution drinks, receptions and other external activities), I can say that, even with a full board, the life of a board member is a busy one, and I wouldn't want to this with a board as small as last years one.

Of course, with my day filled with board activities, there are moments that the electrical engineer in me is starting to miss some excitement: if all went well, the freshmen should be right about finishing one of their most interesting projects this year, the solar inverter, and the sophomores should be trying to get their electronic inverse pendulum (or Segway model) to stop toppling. And, just last week when I was writing this, the Philea lander was successfully planted

on comet 67P, which was also made possibly by some complicated electrical engineering. These are the moments one should remember why this, sometimes quite difficult, study is actually intriguing as well.

Talking about stuff made possible by electrical engineering: the faculty service center decided to showcase the options for the new coffee machines. So if you are wondering why this writing is somewhat unstructured, here is your answer: the coffee for taste was available for free (and, after thorough sampling, I prefer the Maas machine, by the way).

But, if you are drinking something else than coffee right now, I have just what you need:

Dames en heren,
Op de koningin, op Scintilla!



Mickey Derks
President



EWI New Year Drink

Monday 5 January
16:00h, Abscint

SCALA's epic Poker and Klaverjas tournament

Thursday 8 January
20:00h, Abscint

Board Game Night

Thursday 19 March
20:00h, Abscint

Masthead

De Vonk

Periodical of E.T.S.V. Scintilla.
Published four times a year in the amount of 700 copies.

year 33, edition 1
December 2014

Editorial team

Maksym Aleksandrovych, Tim Broenink, Erwin Bronkhorst, Lynn Bruins, Pepijn Ekkelmans, Guus Frijters, Maikel Huiskamp, Bas Keet, Vera Nauta, Jippe Rossen, Ewoud Visser.

Cover Artist

Robert Fennis

Print

Gildeprint, Enschede

Editorial office

E.T.S.V. Scintilla, University of Twente,
Postbus 217, 7500 AE Enschede,
0031 53 489 2810
0031 53 489 1068
vonk@scintilla.utwente.nl

Material

vonkkopij@scintilla.utwente.nl

All members of Scintilla receive De Vonk free of charge by post.

Nothing in this magazine may be duplicated or copied without explicit permission from the editorial team of De Vonk.

The editorial team reserves the right to change or exclude material provided by third parties, in part or in whole. The opinions expressed in the articles are not necessarily shared by the editorial team.

ISSN 0925-5421



Since the first week of this new academic year, our student association Scintilla has a new board with the nice amount of six people. In this article, each board member introduces himself so you know what kind of guys are controlling the association these days. If you want to know more about these people after reading the article, please go to the Scintilla room and drink a cup of coffee with them!

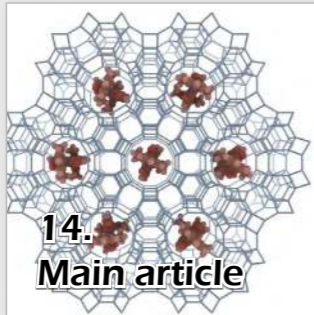

For most of you, it is no surprise anymore that electronics become smaller and smaller. Currently, the feature size of a chip approaches the atomic scale, which requires new techniques to make this possible. At the Nano-Electronics group, research is done on the use of organic materials in electronics. In this article, Wilfred discusses the possibilities of organic materials and chemical interactions in the realization of electronic systems.



In this edition of 'Afterlife', Maurits tells about his life after his study Electrical Engineering. He studied Electrical Engineering at the applied university in Arnhem and after that, he did his master in Twente. In this article, you can read how he applied for the job he is currently having at USE System Engineering and what his daily life looks like. This article might help Electrical Engineers in finding a perfect job after graduation.

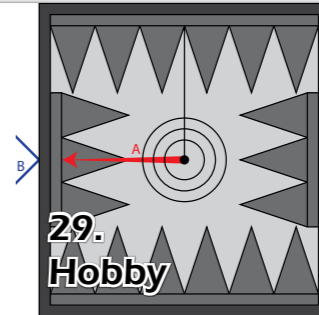

When analysing antenna's, it is important that echoes caused by the environment you are measuring in do not interfere with the measurements. At the Telecommunication Engineering group, Roelof developed a mini anechoic chamber for this kind of measurements, within a frequency range between 1GHz and 10GHz. In this article, he describes the design process of the chamber and he presents the anechoic performance of the chamber.

- 3
- 6
- 8
- 9
- 13
- 14
- 18
- 20
- 22

Presidential note
Halfway there

News
News for the Electrical Engineer

Education
New minor system

The 85th board

Activities
Soldering course

Main article
Hybrid NanoElectronics

Solar Team
Lighter, better, faster, stronger

Photo pages

Bachelor assignment
HTTPS intrusion detection

Green Team
From hydrogen to electricity

Afterlife
From student to hardware electronics engineer

Hobby
Design of a mini-anechoic chamber

Internship
Amazed by the lights

Internship
Homey: Talk to your home

Junction
Jeroen Klein Essink

Column
Ultimate transfer

Puuzle

- 24
- 26
- 29
- 32
- 34
- 36
- 38
- 39

Editorial

Holiday Cheer

During the layout evening while I am writing this editorial, I am overjoyed with the music selection. In this time of holiday cheers it is refreshing to listen to the bloodhound gang. Well, I think we are listening to the bloodhound gang, as the new and improved SK-TVapp currently shows the progress of the Vonk layout. So while working we have to guess what music is playing and we will not notice things on IRC and do not now our current and next lecture. What a shame.

But more about our current activity. We are rushing to finish the Vonk while there is still time to do so. The holidays are getting closer and with them the Scintilla Christmas dinner. I don't think we will be able to work on the Vonk after that, so we will have to be quick. What would be a better christmas gift then receiving a brand new Vonk on your doorstep this christmas? A great example of non-holiday cheer.

So have a great holiday with lots of reading pleasure, and when the festivities become to much for you, just excuse yourself with the fact that you absolutely have to read the Vonk.

Tim Broenink

News for the electrical engineer

Artificial retina developed that could help restore vision

Since most of the population grows older and older, an increasing health problem for many people is loss of eyesight due to retinal degeneration. Researchers from the Hebrew university of Jerusalem, Centers for Nanoscience and Nanotechnology and Newcastle University have developed a new prosthetic retina that could help counter the loss of eyesight.

There are already a number of devices available that can help with visual impairment, but most of the time they involve sending sensory signals to the brain. Patients with the so called age-related macular degeneration could potentially benefit from the new development since the new device does not include the cumbersome metallic parts, wiring or low resolution problems.

The researchers combined semiconductor nanorods and carbon nanotubes to create a wireless, light-sensitive flexible film, which could act in place of a damaged retina. The developed film was tested with a chick retina that did not respond to light. They found that when the film was applied to the chick retina the film absorbed light and in response sparked neural activity.

Source: <http://tinyurl.com/vonk3311>

Nanopore based battery

The last couple of years a lot of research went into the development of small batteries to the point where the anodes consist of only a single nanowire, but in almost all the cases the research was not really aimed at creating a new battery design. Researchers at the University of Maryland have invented a tiny structure that includes all the components of a battery that could bring miniaturization of energy storage components.

The structure of the battery consists of tiny holes in a ceramic sheet called nanopores,

which hold electrical charge between the nanotube electrodes at either end. Many millions of these nanopores can be placed into one larger battery the size of a stamp. The aluminium oxide nanopores contain a liquid electrolyte. Each nanoelectrode includes an outer ruthenium nanotube current collector and an inner nanotube of vanadium pentoxide storage material. These together form a symmetric full nanopore storage cell with anode and cathode separated by an electrolyte region.

Source: <http://tinyurl.com/vonk3312>

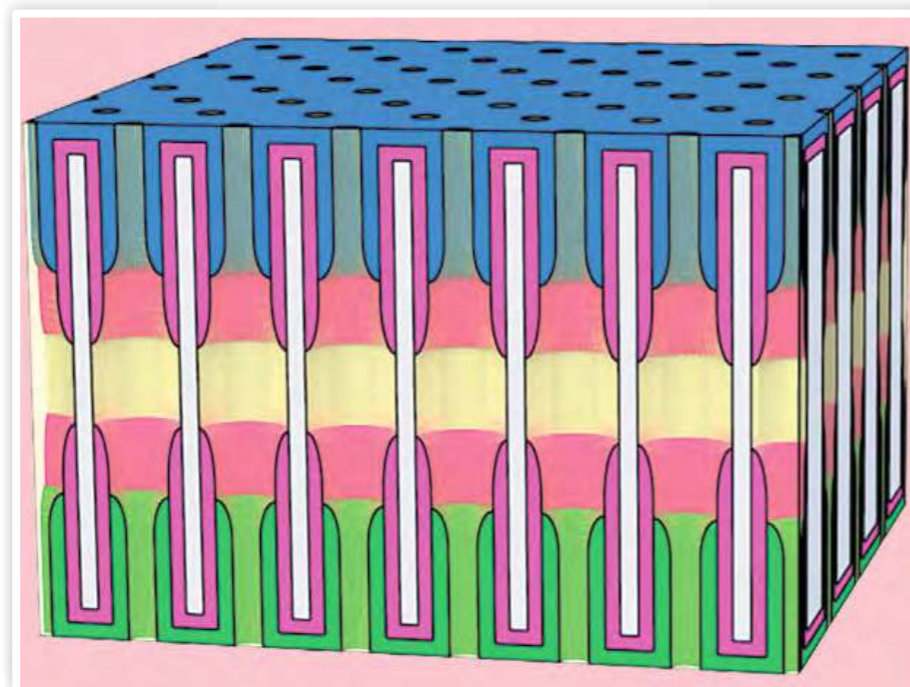

Schematic view of the nanopore based battery

Author: Maikel Huiskamp

First operational terahertz amplifier

The Northrop Grumman Corporation designed the first terahertz amplifier that also made it into the Guinness World Records today. The amplifier was developed under DARPA's program for creating the fastest solid-state amplifier.

Terahertz circuits could be used in telecommunication systems but can also be used in other revolutionary technologies such as high-resolution security imaging, collision-avoidance radar and spectrometers that could detect potentially dangerous chemicals.

The new terahertz circuit exhibits power gains several orders beyond the current state of the art amplifiers. The amplifier has a gain of 9dB at 1 THz and a gain of 10 decibels at 1.03 THz. The transistors are all so called high-electron-mobility transistors made from indium phosphide. The gate length of the transistor is just 25 nm. At these high frequencies the size of the transistors becomes more important. The group of scientists

also planned to design other electronic components in the terahertz range.

Source: <http://tinyurl.com/vonk3313>

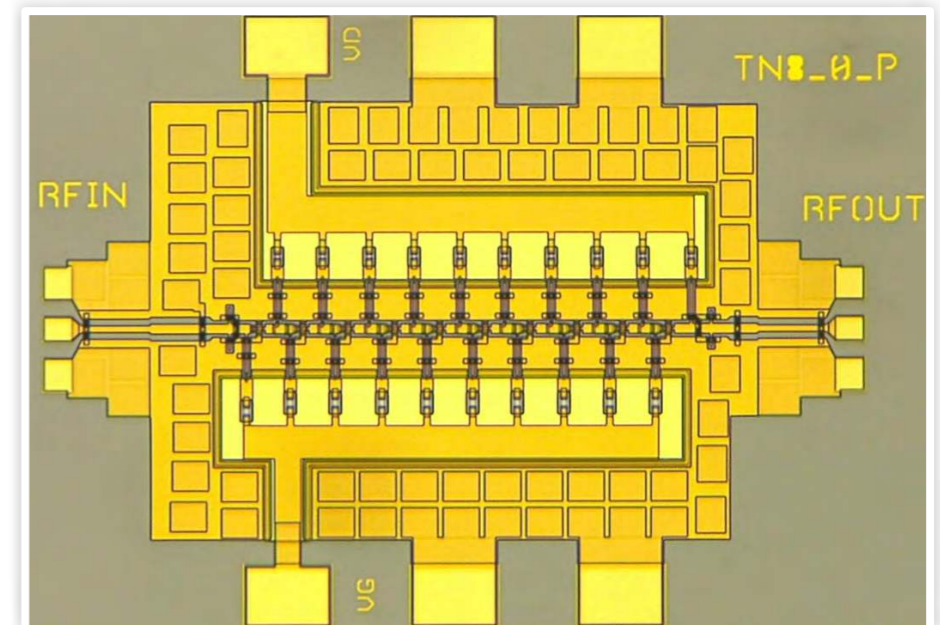

The designed terahertz amplifier.

Refrigerator as wireless charger

More and more wearables are released and most of them have the same problem: battery lifetime. Since the whole point of wearables is to wear them 24/7 so you don't miss a thing and everything can be monitored, from your heart rate to the steps you take each day, the big question is then when to charge your wearable.

One of the obvious answers to the previous question is wireless charging. Many companies have worked in wireless charging via inductive charge that depends on the device being in an electromagnetic field sitting on a charging pad, so you still have to remove the wearables from your body.

The company Energous takes a different approach. Their technology is able to harvest its energy from RF signals. They have deve-

loped a cube of 30 by 30cm that can send up to 4 watt of power in a radius of 3.7 meter and 1 watt at 3 to 4.5 meters. At the above mentioned levels it can charge up to 4 devices. When more devices come within range the power levels drop with each device.

In collaboration with Haiers, which is a large appliance manufacturer, the obvious

guess is to implement the charger in a refrigerator, since in most houses the kitchen is central space in the home. In September this year Energous also made deals with companies that will roll out batteries that can be charged with Energous technology.

Source: <http://tinyurl.com/vonk3314>

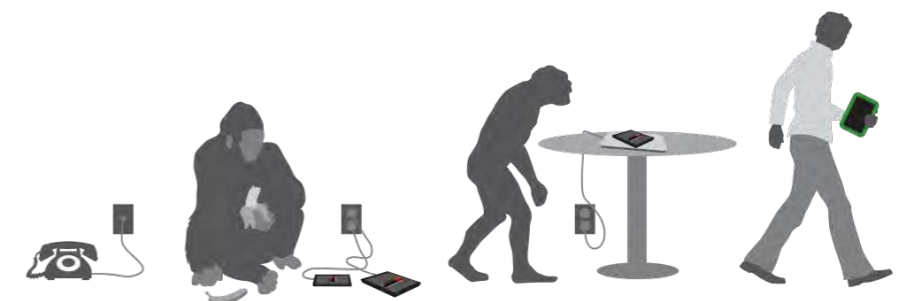

Evolution of charging

New minor system

Author: Roel Mentink

In this article I would like to explain some things about the educational changes that are going on. Currently the university is working on a new minor system that will replace the current one. This new minor system will be implemented next year and the preparations are still not finished yet, so the info below can still be changed.

In the third year of the bachelor's program of Electrical Engineering there used to be a 20EC minor where students were able to follow courses that were not related to Electrical Engineering.

Due to the new Twente Educational model, the minor system is being changed. The old minor system is being replaced by a minor of two 15 EC modules adding up to 30EC. These two minor modules could be filled with two 15EC modules or one 30EC course. Possibilities are broadening modu-

“Broadening courses are multidisciplinary courses that are usually a mix between technology and social studies.”

les, deepening modules or modules from another study program. It will also be possible to follow courses at a university outside of the Netherlands. People however are only allowed to follow one 15EC deepening module, so they always have to follow at least one 15EC module that has got no

relation to Electrical Engineering.

Broadening courses are multidisciplinary courses that are usually a mix between technology and social studies. Some of these courses did also exist in the old system, but there are also new modules. Examples are BioRobotics (15EC), Learning to Teach (2x15EC) and Cybercrime Science (15EC). It will also be possible to follow modules from other studies, at the university of Twente or abroad. Studying abroad can be a great experience and there is financial support available, but you should start arranging this on time. If you are interested in minor abroad, you can look at the following website:

<http://www.utwente.nl/studyabroad/>

It is also possible to follow courses from other studies from the university of Twente. One could follow regular modules in the first semester from the first and second year. Not all modules are open for Electrical Engineering students, because there is too much overlap with EE or there is a lack of prerequisites. It will probably be possible to join a thermodynamics class at Advanced Technology, but following signals and systems courses would not be allowed. There will come a matrix with more information soon.



There will probably also be deepening modules. These are electrical engineering modules that will focus on some specific EE fields. These are still in progress, so I can not tell much about these right now, but there

“Studying abroad can be a great experience and there is financial support available.”

will be more info available soon.

As I already explained, the new minor system is still in progress and everything can still be changed. The final version of the new minors will probably be public around march.

If you did not finish your minor yet and do not follow the TOM-education, you should visit your study advisor to have a talk about your minor. For more information about the new minor, visit <http://www.utwente.nl/profileringsruimte/en/>

The 85th board

Author: The 85th board

Previous year, the Scintilla room was relatively quiet, with only three board members. They did their best to assemble a bigger board for this year, and with succes: This year's board is six men strong. Together they'll try to improve on a few issues, like improving the internationalization of Scintilla even more, and improving on all the small issues. But most of all, they'll try to enjoy themselves. They've all written a piece to introduce themselves.



“We can however give you our word that we will try our best to enjoy our next year within Scintilla as much as possible and hopefully make it more enjoyable for other members as well.”



Mickey Derks

President



Being a board member for E.T.S.V. Scintilla has always appealed to me: I loved the introduction cantus during my Kick-In camp, with the entertaining and inspiring performance by the senate, which is also the first memory I have of Scintilla board members, and I always enjoyed spending time in the Scintilla room, whether it was just meeting people or trying to focus on studying. I also joined the Parents Day committee and the SOT during my first year.

When the 83rd board was struggling to assemble the previous board, unfortunately, I couldn't (as a freshman) be of more use at the time. Nevertheless, I wanted to do something besides my study, so I joined the Green Team Twente. As a diligent Scintilla member, you should be able to read their article in the previous Vonk, which you of course have carefully archived, but if you somehow lost it, you can always download it from the website or come talk to me. I also

Some might say they had long seen it coming that I was going to be a board member, far before even I knew this. I started my study Electrical Engineering in the year 2011: the last year in the Dutch speaking era. I chose this study for its relation between theory and practice: every piece of theory is put into practice in a lab assignment or project. I thus consider my study a form of high-tech hobbying.

With a lot of hard work I kept up with my curriculum and became an active member at the end of my first year as the chairman of the "Spark" committee, the aim of which was to promote hobbying in the field of electrical engineering. This committee was an experiment and was abandoned not much long after, but it did yield the Scintilla Soldering Course as one of its fruits. Since then I have organized multiple activities, all in the field of hobbying.

As I had been on the list of "people who are going to be on the Scintilla board, but do not know it yet" for quite a while, I was delicately asked by the previous board to function as the committee contact person for the Freshmen Committee, as to slowly push me towards more Scintilla responsibility. A successful move, considering in the position I am in now.

This year I am the secretary of Scintilla and I plan to finish the last few subjects for my bachelor's degree. Why secretary? Well, for a start I like the overly formal "bralen" (Dutch). A word for which there is no correct English translation that I am aware of. Furthermore I am a language fanatic in both Dutch and English. Combined with the fact that I am not at all suitable for functions which require a sense of nuance, I was the obvious candidate to become Scintilla's secretary.

joined the SKIC, to help organize the Kick-In camp for electrical engineers, which was at least as exhausting as the GTT, but definitely worth it.

After a year of hard work, sometimes even studying enough to just pass all but one course, I still didn't feel like studying full-time again, so I decided I still wanted to join the Scintilla board. For me, being part of the board is the ultimate possibility to help make all of our beautiful activities possible. As the president of this board (and still the youngest board member), it is my task to lead this board through not just the fun, but also the stressful situations. Last year, dealing with these was not that much of an issue: they just provide the incentive to work harder when required. I hope this will, when needed, be the case this year as well, but I have faith that we will be able to keep this need to a minimum, and that it will be another great year for Scintilla.

Joep Zanen

Secretary



About one and a half years ago, I decided I'd join the board of Scintilla. Not the next year though, I wanted to finish (or at least almost finish) my Bachelor's degree first. This was due to the 'sociale leenstelsel', which means that you're fucked (financially) if you start your Master's September 2015 or later. If I'd decided to join the board one year ago, I wouldn't have been able to finish my Bachelor's before that date, so it didn't seem smart to do so. I was right; a few weeks ago I finished my Bachelor's degree. Now that I've done so, I can fully focus on the board of Scintilla without being fucked by the 'leenstelsel'. I will use this year to also plan my Master's degree, find out which specialization I want to do and make a course planning for this specialization.

In my first year, I became an active member of E.T.S.V. Scintilla, as a member of the parents day committee. In the years after that, I only did more: STORES (se-

Jippe Rossen

External Affairs



To many of you it had come as quite a surprise that I joined the 85th board of this wonderful association. Being a fifth-year student I am quite a quite old (or rather ex-

cretary), SOT, Borrel and External affairs, to name a few. I also joined the iDB-committee of the Kick-In, with which we created a complete new backend for the Kick-In last year which helped getting the event organized better than ever. Last year, I got my BHV diploma for Scintilla and helped the previous board to find a new one (this board).

Numbers have always intrigued me. This is not strange, if you take the mathematical focus of the Electrical Engineering program into account. Therefore, the position of treasurer was a very logical choice for my function within the board. It also came with many responsibilities, a competence I wanted to train as well. But being treasurer isn't only about finance. The past two months, I already helped organize some events, set up the SRC (Study Tour Committee), Sympo (Symposium committee), and organized the BHV planning for every activity since. It is fun!

perienced) board member. Many people assumed I would have joined the board either sooner, or not at all. In my previous years at the university I have been a quite involved member. I have been present at most general meetings in the past and have always had a big interest in the ins and outs of this association. During my fourth year I came to realize that, despite some medical setbacks, I was able to finish my bachelor electrical engineering within four years. During the period I came to evaluate what I loved doing in life and what I yet still wanted to learn while I was still able to, without being bound to some job.

This all eventually let me to the conclusion that I could yet develop myself further while doing things I loved. After some weeks and many pros and cons lists I decided to, at last, join the board of Scintilla.

During the previous year I had already been a part-time semi board member by being active in the external affairs committee. During that year I had been responsible for the contact with three companies. Now I am fully responsible of all interaction with our partner companies, as well as other contacts. What I hope to achieve is that all our sponsors are content with our current servi-

Tobias Feijten

Treasurer



ces and also to explore and set up new forms of partnerships.

Originally I grew up in Deventer. During my childhood, I played football for about twelve years. As I was already exceptionally tall at that age, only a year passed before I was the picked to become a goalie. I enjoyed practice more than the actual matches, because I really liked the physical intensity that the goalkeeper is put through during training sessions. If you have a hard time imagining this, come find me at the Scintilla room and I will show you what goalkeepers will have to endure. Nowadays the only sport I do is jogging. It really helps me to relax and process all the problems and troubles I might have. I find it really relaxing to put on some tunes, set my vision to infinity and to just run.

Besides sports I also love music, though I am not a true audiophile. You will not hear me going on about rhythm patterns, or chord progressions, or the exact difference. This interest in music resulted from the purchase of a total of 3 guitars (so far), even though I never had any musical education. Four years ago I bought a guitar (with the help from some friends from high school)

and just started playing until I succeeded in playing the whole song I set my mind to. A year ago this also led me to designing my own guitar effect pedals. I have already finished three so called 'stomp boxes' and I am now working on a fully programmable digital effect, which I hope to complete during the next couple of months. This might, however, prove very hard with all the distractions and awesome activities a board function presents!

My name is Roel Mentink and currently I am in my fourth year of my study Electrical Engineering. This year I will be the commissioner of internal and educational affairs of the E.T.S.V. Scintilla. In the past this function was often described by the Dutch word "Ledencoördinator", however in the last couple years we often did not have this board function.

So far, during my student life I have been quite active already. In my first year, I have joined the parents day committee. In my second year I joined the Scintilla's Kick-In Committee and the Green Team Twente and in my third year I decided to join the Borrel. I also supervised the parent's day committee of last year, because the 84th board did not have the time available to do so themselves. After all these years of studying I have joined the board, because I wanted to do something different.

As a commissioner of internal and educational affairs I am talking to a lot of different people and am attending a lot of meetings. You need to keep contact with students, university staff members and other study associations in order to address problems. I think we have formed a great 85th board and I am confident that we will be able to deal with all problems that we will be confronted with.

Roel Mentink

Internal & Educational Affairs



Eelco Bussink
Administrator



As an alleged "oude lul", the choice to become an administrator and thereby board member of Scintilla was (maybe) disputed, and not the least by myself. But, since Scintilla has been great to be a member of, a board sided view was an easy enough choice. To finish this already way to long introduction, being an administrator as opposed to a full time board member would impact my desires of finishing my bachelor by a lesser degree. So far, not much has been said. Maybe my efforts for making this easy to read are already futile, after just the first sentence. For which I am not extremely sorry.

Of course, I could write excessively about my history, how I was born (something with my parents having a stork delivery service over), but that is not interesting. Until the time I went to the university, I played soccer, but, after problematic limb structures and driving into a truck, that's off the table. Now, my focus is on lifting weights, putting them down, and mountain biking. Occasionally you will find me training my liver at the Abscint, an activity in which you may always accompany me.

As you can read, the material I am writing about is not that interesting, so maybe a story about Charlie the Unicorn can lighten things up a bit. A trip to candy mountain will be a trip to heaven, for your mind remember all the times you have been up there with Charlie. Perhaps you can take a quick thought about all the hours you have wasted watching Master Movies, which in my mind are very nostalgic. Let's hope at least a few readers of this little introduction are now tempted to watch Charlie the Unicorn or Master Movies again.

I will not linger on with this introduction for much longer. The easiest way of telling who you are or getting to know a person is by, well, meeting in person. If you really want to get to know me, come to have some coffee with me and then we could talk about random stuff like Charlie the Unicorn, Master Movies or some frustrating bureaucratic facts. This concludes my introduction, and as Einstein once said: "The difference between stupidity and genius is that genius has its limits."

Soldering Course

Author: Course Committee

Although Soldering can be seen as an outdated art, and is not always needed during the study, it is a basic skill every electrical engineer should have. Like mathematicians have their math, an electrical engineer has his soldering iron.

Since not every first-year student had parents or someone else to teach them soldering, Scintilla started the soldering course. In the previous years, generally more than half of the class did not have the opportunity to learn soldering, and signed up for the soldering course.

Just after the first-years finished their re-takes and were about to start their first project, they took up the challenge to solder a small amplifier. They course kicked off with a soldering presentation. After that, upon receiving their soldering kits and heating their soldering irons, they got started. First, they inspected their given circuit, checking if they had all the

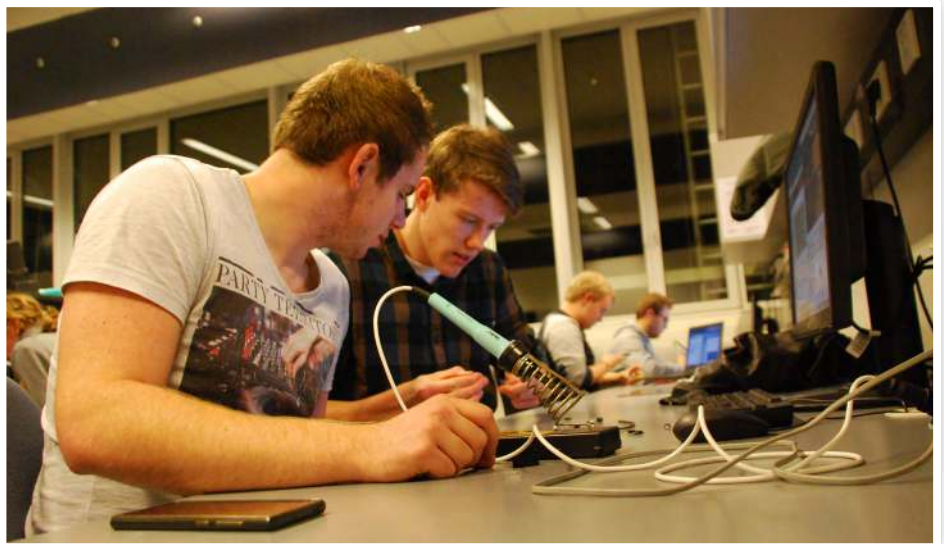

components, and planned how to fit it all on their soldering board.

After finishing (or giving up on) their planning, they soldered away, and after another evening and a half, a majority finished at least the soldering stage of their amplifier. While the stragglers were busy soldering, the rest were debugging their amplifiers. As the evening progressed, more and more wanted to test their amplifier. After a while, the 'Westzaal' Lab was filled with the melodic masterpiece that is "Luv You More".

Hybrid NanoElectronics

Author: Wilfred van der Wiel

The dazzling miniaturization of electronic components over the last decades did not only make electronics more powerful, but also kept it affordable. The omnipresence of electronics in our daily lives proves that. When electronic devices approach the scale of atoms and molecules, one faces the enormous challenge of controlling the device geometry and preventing detrimental device-to-device variations. In the meantime, truly exciting (quantum) physics arises, which might be harnessed into novel functionality. Until recently, inorganic materials, predominantly silicon, have played the leading role in the semiconductor industry. The application of organic molecules offers a range of new possibilities, especially now the dimensions of electronic components approach the molecular scale.

Organic materials, like plastics (from the Greek *πλαστικός* – *plastikos* – which means moldable), were for a time only associated with electrical insulators. It is for a good reason that we protect our electrical wires with plastic covers. In the second half of the last century, however, the idea of organic electronics arose. On the one hand, there was the wish to apply the easily processable organic materials as (semi-)conductors in bulk or thin-film form. On the other hand, the concept of using single molecules as electronic components such as diodes and transistors was launched. This latter idea is also referred to as molecular electronics. The advantages of organic materials are, besides easy processability, the possibility for chemical modification of the electronic functionality, mechanical flexibility and the possibility for self-assembly. These properties can for example be exploited in the production of relatively cheap electronics for large surfaces. Single molecules might perhaps become part of ultimately

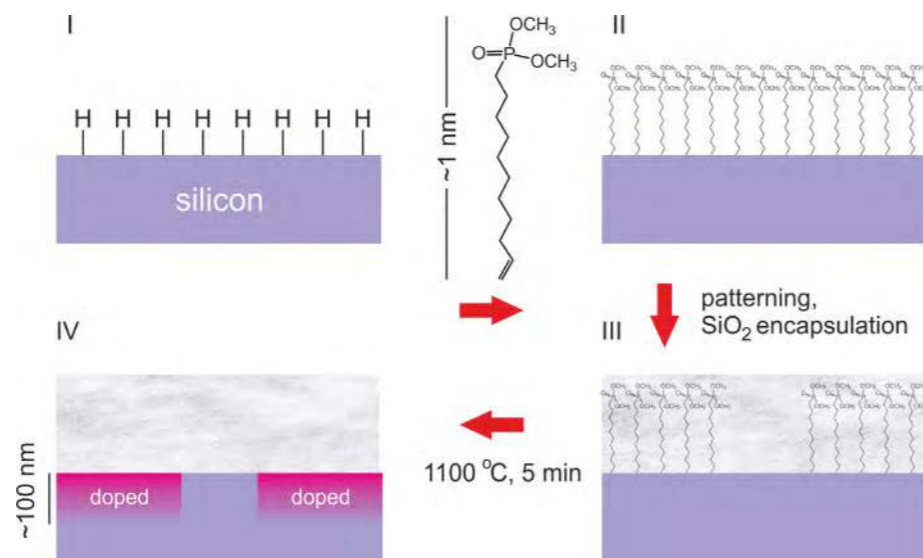

Figure 1: Schematic representation of molecular layer doping of silicon (not to scale) I: The natural SiO_2 is removed by NH_4 and a hydrogen-terminated (Si-H) surface is created. II: A full monolayer of molecules (1-undecenyl-dimethylphosphonate) containing the donor atom phosphorus (P). III: Nano imprint lithography combined with an oxygen plasma etch is used to pattern the monolayer at the micronscale. After that, the patterned monolayer is encapsulated in SiO_2 to prevent loss of the molecules in the subsequent thermal in-diffusion step. IV: During this last step the molecules fully disintegrate and the P atoms diffuse (partly) into the silicon [1].

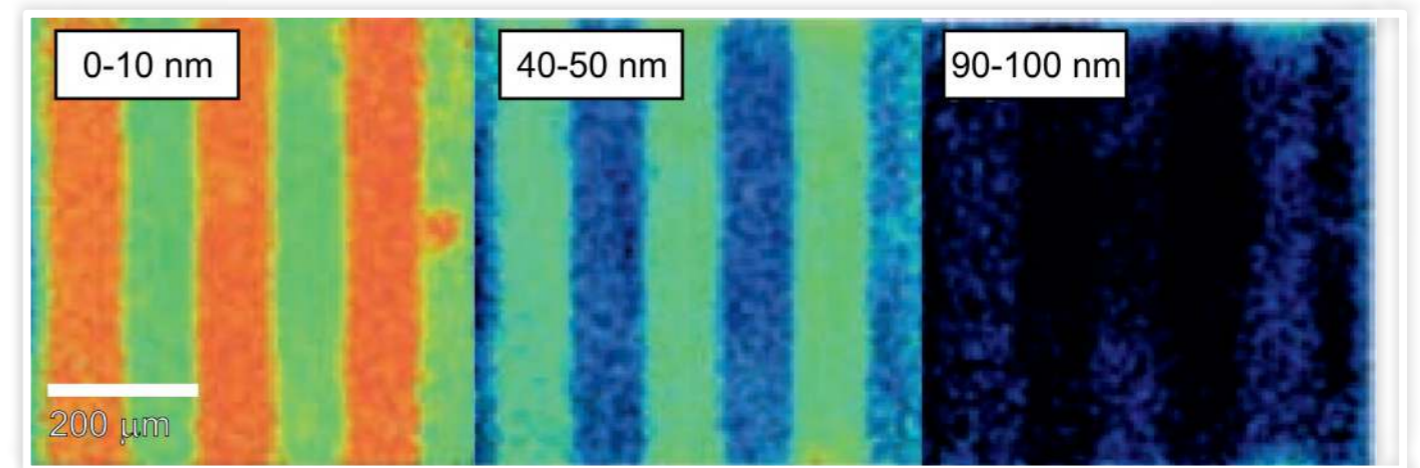

Figure 2: Phosphorus element analysis (normalized at silicon) for three different depths. The measurements are performed with secondary ion mass spectroscopy (SIMS). The (false) colors correspond to increasing phosphorus concentration from black to red, via blue, green and yellow [1].

miniaturized electronics, although still tremendous challenges exist.

In this article, I would like to discuss especially the possibilities that organic materials and chemical interactions can offer for the realization of interesting test bed systems for future electronic devices. Conventional electronics mainly makes use of top-down fabrication. Here, technologies such as photolithography or electron-beam lithography are used to define small patterns on a wafer. When lithography is combined with ion implantation, metallization and etching, one can define nano- or micronscale devices. Hence one works from “big to small”. Molecular materials offer the possibility for bottom-up fabrication, i.e. working from “small to big”, making use of the concepts of molecular recognition and self-assembly. As a matter of fact, all living systems are the product of such a bottom-up process. As the typical dimensions of electronic components gradually approach the molecular scale, the application of molecules as building blocks or as scaffold becomes more and more realistic. Particularly interesting in this respect are two-dimensional self-assembled monolayers (SAMs) and one-dimensional molecular wires. Below we discuss some recent work from our group and collaborators that nicely illustrates the power of these systems.

Molecular doping of semiconductors

For the manufacturing of electronic components, and in particular for transistors, semiconductors are used. As the name suggests already, a semiconductor does not conduct as well as a conductor like a metal. In fact, a semiconductor looks much more like an insulator, but one that can be made conductive relatively easily by raising the temperature or by doping the material with guest species that donate charges. By doping with electrons or, oppositely, by the removal of electrons (that is doping with ‘holes’), free charge carriers can be created. The concentration of free carriers (typically $10^{13} - 10^{19}$ per cm^3) is still much lower than in metals ($\sim 10^{22}$ per cm^3). Exactly this lower concentration makes it possible to electrically manipulate the carrier density in a device, which is technologically a very important property. The fact that one can dope the same (silicon) crystal both with electrons (n-type) and holes (p-type) allows for the realization of complementary metal-oxide-semiconductor (CMOS) technology.

Silicon is still the most important material in the semiconductor industry. The semiconducting properties of silicon strongly depend on the doping concentration. For the introduction of extra electrons phosphorus (P) is being used, for the introduction of holes boron (B). Normally, donors are introduced by a technique called ion

implantation. The silicon is being bombarded with a high-energy (10 – 500 keV) ion beam to insert the desired doping atoms in the silicon. To repair the damage of the bombardment, and to electrically activate the dopants, the silicon is subsequently heated up to high temperatures (typically 1100 degrees Celsius), the so-called annealing. In this step, the dopants diffuse into the silicon. With the decreasing size of electronic components, one needs more and more control over the lateral positioning and penetration depth of the dopants.

Together with colleague Prof. Jurriaan Huskens of the Molecular Nanofabrication group, we asked ourselves whether molecular self-assembly could play a role in the positioning of dopants in silicon. A method was developed to form a molecular monolayer containing dopant atoms directly on the silicon, and to pattern it subsequently [1], see Figure 1. Hereby use is made of a specific chemical binding between the silicon and the molecules with dopants, so that the silicon is covered with only one layer of molecules. The molecules that do not bind to the silicon are simply washed off. The monolayer is being patterned with a technique called nano imprint lithography (NIL), a nanoscale stamping technique. In this way, we could selectively cover the silicon surface with the monolayer. The patterned monolayer was encapsulated in silicon oxide, after which a rapid thermal annealing (RTA) step was performed to diffuse the dopant atoms in the molecules into the silicon. By limiting

the annealing time, the dopants mainly end up in the top 100 nanometer of the silicon. The patterned monolayer allows for easy, local control of the dopant concentration.

Using the method described above, we have shown [1] that we can define micronscale phosphorus doping patterns in silicon, see Figure 2. In the doped regions, a surface dopant concentration of $(2.3 \pm 0.1) \times 10^{19}$ phosphorus atoms per cm^3 was measured, corresponding to a surface density of $(5.6 \pm 0.1) \times 10^{13}$ phosphorus atoms per cm^2 in the silicon. If we compare this with the maximum surface molecular density of the monolayer which is $(2.2 \pm 0.1) \times 10^{14}$ phosphorus atoms per cm^2 , we find a doping efficiency of 26% in the patterned samples and of 50% in the unpatterned samples.

With the help of molecular monolayers it is thus possible to locally change the electrical properties of a semiconductor by the implantation of dopant species contained in the molecules. Molecular layer doping has a number of potential advantages in comparison to conventional doping methods like ion implantation. (1) The damage inflicted by ion implantation upon nanoscale 3D devices is generally more severe than in the case of planar geometries. The non-destructive character of molecular layer

deposition is a huge advantage here. (2) Ion implantation is highly directional, making it very hard - if not impossible - to homogeneously dope a non-planar device. (3) Directional doping techniques suffer from 'shadowing' effects, in particular when the spacing between non-planar devices is comparable to the device dimensions (which is normally the case).

Presently, we are working on reducing the lateral dimensions of the doping patterns to the nanoregime and to minimize the implantation depth. In addition, we want to tune the doping concentration by diluting the monolayer with molecules that do not contain dopant species. It is also an interesting question whether with a comparable molecular monolayer method one can implant magnetic species in an otherwise non-magnetic material, thereby introducing magnetic properties. The introduction of even a very small number of magnetic impurities in a metal can already have a dramatic effect on the physical properties, like the electrical resistance or the magnetic susceptibility. We have recently succeeded in doing this for a thin film of gold [2], showing that one can reach magnetic species concentrations as high as 800 parts per million (ppm).

Ultrahigh magnetoresistance in molecular wires

Systems featuring large magnetoresistance (i.e. a resistance change in a magnetic field) at room temperature and in small magnetic fields are strongly sought-after due to their potential for applications in magnetic field sensing and data storage. Usually, the magnetic properties of materials are exploited to achieve large magnetoresistance (or MR) effects. Typical examples consist of multilayer stacks of ferromagnetic materials separated by either a non-magnetic metal spacer layer, as in the case of giant magnetoresistance (GMR), or by a tunnel barrier, as in the case of tunnel magnetoresistance (TMR). The resistance of these structures is strongly dependent on the relative orientation of the magnetization of the magnetic layers, and can therefore be altered by an external magnetic field. The 2007 Nobel Prize in Physics was awarded to Fert and Grünberg for the discovery of GMR. Moreover, GMR and TMR magnetic field sensors are widely applied nowadays, in particular in hard disk read heads. Room-temperature TMR values over 600% have been realized in epitaxial magnetic tunnel junctions. Re-

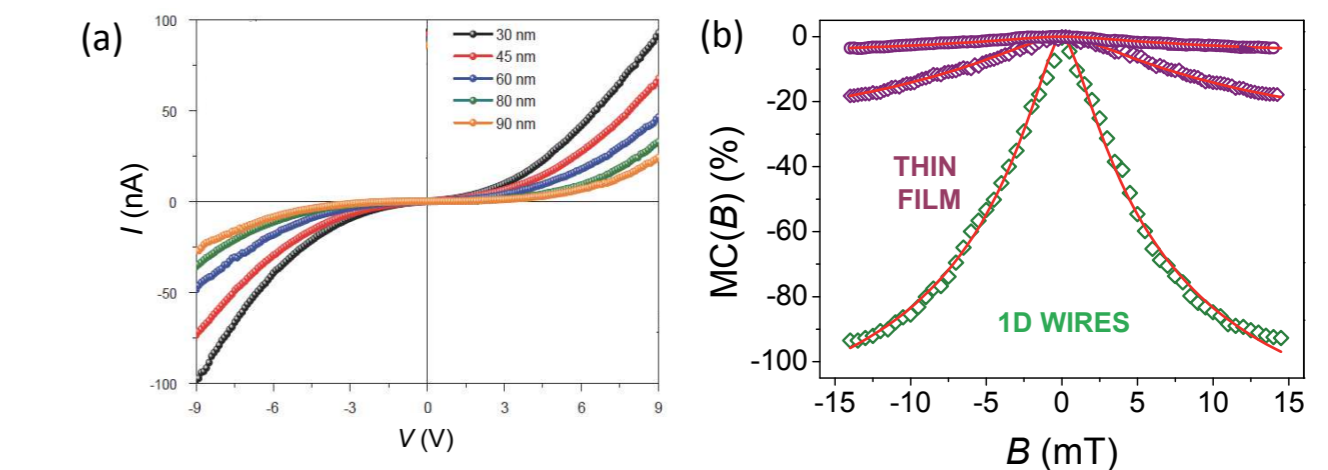

Figure 4: Ultrahigh magnetoresistance at room temperature in molecular wires [3] (a) Room-temperature I-V characteristics for different channel lengths. (b) Comparison between magnetoconductance (MC) in a ~ 40 nm DXP film measured by a $250 \mu\text{m}$ diameter Pt wire (purple circles), the same film measured by a CP-AFM PtSi tip (purple diamonds), and 60 nm long 1D DXP wires measured by a PtSi CP-AFM tip (green diamonds). The red curves are fits to Eq. 2.

cently, we have explored entirely different physics in a non-magnetic system of highly ordered organic molecules. Room-temperature MR values over 2000% in 1D chains of molecules enclosed in zeolite crystals were found [3]. This is one of the largest room-temperature magnetoresistance effects ever observed for such small magnetic fields.

In collaboration with the group of Professor Luisa De Cola at the University of Strasbourg, we have used zeolite L crystals as a host material for the 1D organization of organic dye molecules (DXP), see Figure 3a. The geometrical constraints of the zeolite L host structure allow for the formation of separated, 30-90 nm long 1D chains of highly uniaxially oriented, closely spaced molecules (a few tens). The truly fascinating

$$MC = \frac{I(B) - I(0)}{I(0)} \quad (1)$$

nature of this system lies in its behavior in a small magnetic field, where an unprecedentedly large and robust magnetoresistance effect is observed. The experimental setup is schematically shown in Figure 3b. A conducting-probe atomic force microscope (CP-AFM) measures the electrical conduction of the 1D DXP wires. A few tens of wires are measured in parallel due to the finite curvature of the CP-AFM tip.

Figure 4a shows the room-temperature I-V characteristics, which are typical for energetically disordered systems with hopping transport, with a resistance increasing with wire length. The magnetoconductance MC, defined as

$$MC(B) \propto \frac{B^2}{(B_0 + |B|^2)} \quad (2)$$

and $I(0)$ the current at zero magnetic field, is shown in Figure 4b both for a thin film of DXP (purple symbols) and 60 nm long DXP wires (green symbols). The MC of the 1D wires approaches the maximum possible value of -100% and is much larger than the thin-film MC. These results strongly suggest that confinement of the current path is crucial for explaining the large MC, in line with theory. All $MC(B)$ curves can be well fit with the empirical line shape

applied before in the context of organic magnetoresistance.

The magnetoresistance effect is ascribed to the interaction between the electrons and the magnetic field which is generated by the surrounding atomic nuclei in the organic molecules. Current suppression in a small magnetic field can ultimately be traced back to the famous Pauli exclusion principle, the quantum mechanical principle that states that no two electrons (fermions) may have identical quantum numbers. Since the elec-

tric wires are essentially one-dimensional, the effect of the Pauli exclusion principle is dramatic, comparable to an accident on a single-lane road that brings traffic to a standstill. This interpretation is supported by calculations.

The mechanism that is responsible for ultrahigh magnetoresistance in molecular wires is possibly closely related to the biological compass used by some migratory birds to find their bearings in the geomagnetic field. We are conducting follow-up experiments in the hope to be able to shed more light on this analogy.

References

- [1] W.P. Voorthuisen, M.D. Yilmaz, W.J.M. Naber, J. Huskens en W.G. van der Wiel, Local doping of silicon using nanoimprint lithography and molecular monolayers, *Adv. Mater.* 23, 1346 (2011).
- [2] T. Gang, M.D. Yilmaz, D. Ataç, S.K. Bose, E. Strambini, A.H. Velders, M.P. de Jong, J. Huskens en W.G. van der Wiel, Tunable Doping of a Metal with Molecular Spins, *Nature Nanotechnology* 7, 232 (2012).
- [3] R.N. Mahato, H. Lülff, M.H. Siekman, S.P. Kersten, P.A. Bobbert, M.P. de Jong, L. De Cola and W.G. van der Wiel, Ultrahigh Magnetoresistance at Room Temperature in Molecular Wires, *Science* 341, 257 (2013).

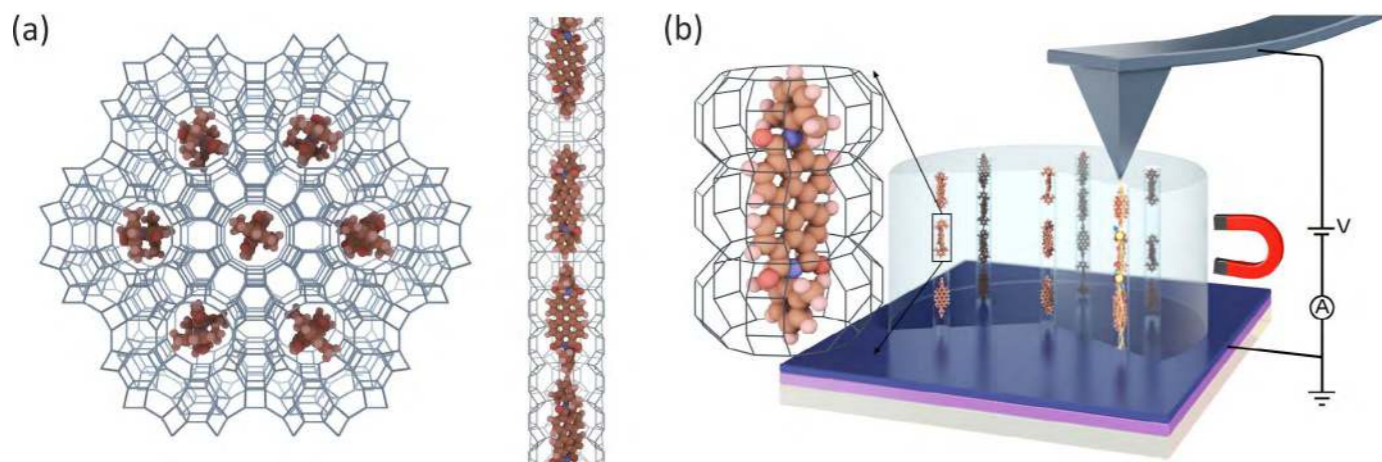

Figure 3: 1D molecular wires embedded in zeolites and CP-AFM setup of Ref. [3] (a) Left: top view of zeolite L crystal loaded with DXP (N,N' -bis(2,6-dimethylphenyl)-perylene-3,4,9,10-tetracarboxylic diimide) molecules. Zeolite L is an electrically insulating aluminosilicate crystalline system, which consists of many channels running through the whole crystal and oriented parallel to the cylinder axis. The channels have a maximum diameter of 1.26 nm and an entrance diameter of 0.71 nm. The geometrical constraints of the zeolite host structure allow for the formation of 1D chains of highly uniaxially oriented DXP molecules. Right: side view. A DXP molecule is 2.2 nm long and the ~ 50 nm long channels are therefore filled with a few tens of molecules. (b) Schematic conducting-probe AFM measurement setup.

Solarteam

Lighter, better, faster, stronger

Last September a group of nineteen enthusiastic students started working on the design of a solar powered car, to participate in the World Solar Challenge 2015. The World Solar Challenge is a 2-yearly 3000 km race from Darwin to Adelaide and will start in October 2015. The cars may only be powered by solar energy. Robin Lohuis, Koen Oosterwijk and myself, Fieke Hillerström, are responsible for the electrical design of the solarcar.

Solar Team Twente started in September 2014 with the concepts and the design of their new car. The road from concepts to the start of the World Solar Challenge, includes designing, prototyping, producing and testing the whole car. The team consists of nineteen students from Saxion and University of Twente, from different fields. Part of them is responsible for the management of the team, others for the communication and visibility of the project. Robin, Koen and myself are part of the technical team, which will design and produce the solar car. In the technical team we work together with people from mechanical engineering, which design the body and mechanical parts of the solarcar. It is really interesting

to work in such a large team, with different people with different specialties.

“You have to focus on different subprojects at the same time.”

Working in the solarteam means working on a large project, in multiple areas. You have to focus on different subprojects at the same time. During the concept and design phase of the project, we started with planning, brainstorm and listing demands. Together we came with all kind of different

Author: Fieke Hillerström
Photo's: Jerome Wassenaar



ideas and things to improve. Besides the technical parts, you also get in contact with companies and get the chance to get a better look inside.

“Every year solar cells with a higher efficiency are produced.”

The electrical design of a solar powered car contains several parts. First of all the solar panel itself of course. Due to the regulations it is allowed to carry or 3 m² gallium arsenide solar cells, or 6 m² silicon solar cells. The solar cell industry is a high developing one. Every year solar cells with a higher efficiency are produced. To be able to gain as much energy as possible, we want solar cells with

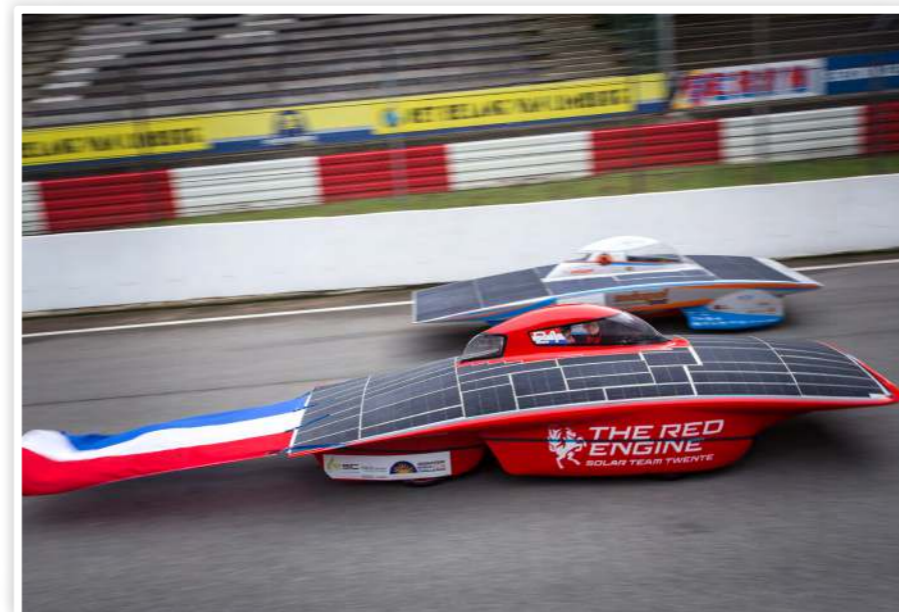

the highest possible efficiency. The energy obtained by the solar cells is stored in a battery pack. Because the voltage coming from the solar panel is different from that of the battery pack, a DC-DC converter is placed in between. Several solar cells are placed in series, under one DC-DC converter. The power coming from a solar cell depends on the conversion rate of the DC-DC converter. The current coming from solar cells changes due to the differences in the radiating solar energy. To gather the maximum possible energy, the conversion rate of the DC-DC converter is changed over time,

the information is analyzed and used to determine the best race strategy. The system used to send the sensor information to the following car, is the telemetry system.

At the moment we are designing the electronics of the powertrain and telemetry system. In a few weeks we will start with the production phase of the project in which the designed parts will be realized and combined. Of course we will test every part of the car thoroughly, to be sure it will work perfectly during the race in Australia.

Last October we had our first race, the European Solar Challenge on the circuit of

Zolder, at which we participated with The RED Engine. It was a really good weekend for us as a team. We learned a lot, about the team itself, about the solar car and about being a racing team. It made us even more enthusiastic and I am looking forward to October the 18th, the start of the World Solar Challenge. We are aiming for a solar car that is lighter, better, faster and stronger.

“To gather the maximum possible energy, the conversion rate of the DC-DC converter is chaged over time.”

which is done by a Maximum Power Point Tracker (MPPT). The energy from the battery pack is used to drive the solar car, using an electrical motor. These elements, the solar panel, the MPPTs, the battery pack and the motor, are part of the powertrain.

Besides the powertrain is the telemetry system. During the race, information about the sensors in the car is obtained and sent to the car driving behind the solar car. There



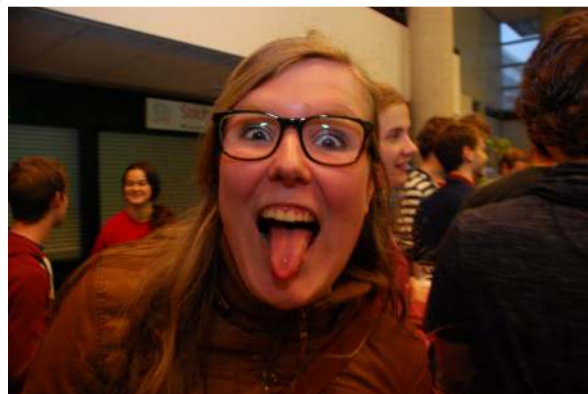
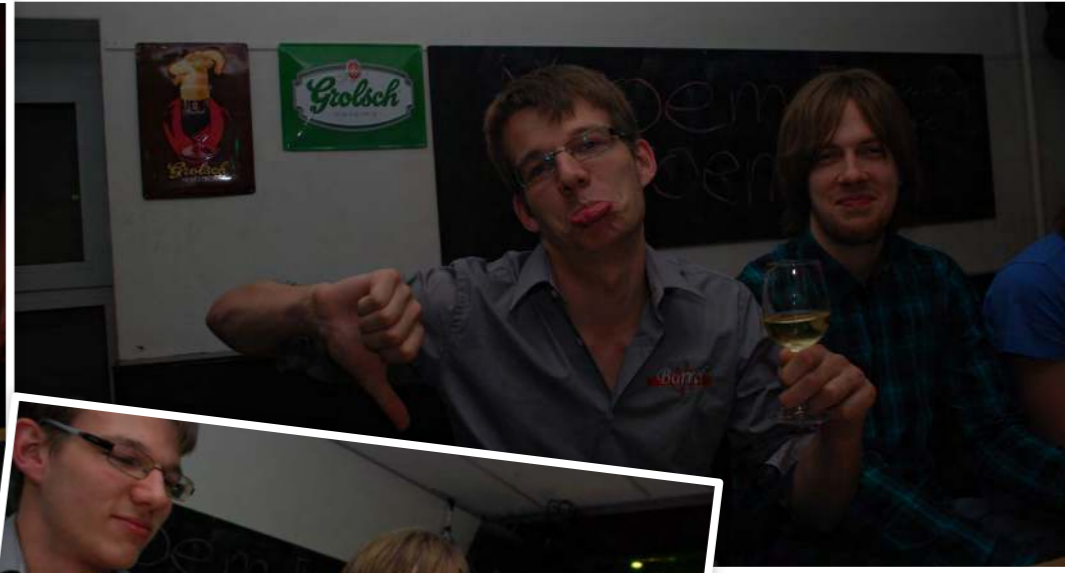

HTTPS intrusion detection

Author: Olivier van der Toorn

My Bachelor assignment was the perfect way to decide at which chair I wanted to follow the Electrical Engineering Master. I was interested in both the Design and Analysis of Communication Systems (DACs) chair and the Telecommunication Engineering (TE) chair. I decided to do my Bachelor assignment at the DACs chair. All of the assignments that they offered me were on state-of-the-art topic: cloud networks for mobile providers, dimensioning link capacity, etc. I chose to join forces with Rick Hofstede. His assignment was about HTTPS Intrusion Detection.

What does 'HTTPS Intrusion Detection' mean? Even though the term HTTP(S) is clear for most of you, I am going to give an analogy anyway, as it will help explain other things as well. Suppose that instead of visiting websites with your browser you want to physically hold the Web pages in your hand. You send a post-card to Scintilla requesting their home-page. The Web server, reads this request, prints the page, puts it in a package, and sends it to your door through PostNL. You open the package and view the Web page. In this scenario PostNL can be compared to HTTP. For HTTPS it can be imagined that the package is given a lock of which only the sender and receiver have the key. With 'intrusion' most people think of a burglar breaking into their home and stealing all their valuable items. For the Web this is quite similar. But instead of a

home there is the back end of a Web site. And instead of a door there is an authentication mechanism. In my research I have looked at brute-force attacks against three authentication mechanisms: HTTP Basic Authentication (BA), Form-based Authentication (FA) and XMLRPC. A brute-force attack is simply trying many login combination of usernames and passwords. These brute-force attacks usually use a list of commonly used login credentials, also known as a dictionary, which is why these attacks are referred to as dictionary attacks.

Dictionary attacks typically feature three phases, as graphically shown in Figure 1. The first phase is the 'scan phase'. In this phase an attacker scans the network for the targeted services. The second phase is the 'brute-force phase', this is the phase where



all the login credentials are tried out. This can end in two ways, either no valid credentials are found and the attack is ceased. Or it ends in the 'compromise' phase, here the attacker has gained entry to the back end and is, for example, able to upload illegal content.

"You send a post-card to Scintilla requesting their home-page."

Brute-force attacks are usually detected by analyzing access logs, if they are detected at all. This host-based approach is hardly scalable in larger networks, since access to the logs is required. Besides the host-based approach, a network-based approach can be taken as well. This approach can be divided into two categories: a packet-based and flow-based. To explain packet-based Intrusion Detection Systems (IDS) we return to our PostNL analogy. These kind of IDSes open each and every packet that passes by to

Authentication method	PPF		BPF	
	HTTP	HTTPS	HTTP	HTTPS
BA	5 - 6	7 - 9	372 - 438	979 - 1239
FA	5 - 9	7 - 12	363 - 736	1022 - 1739
XMLRPC	5 - 6	7 - 8	770 - 889	1491 - 1558

Table 1: Attack signatures based on PPF and BPF

analyze their contents for malicious traffic. As you've likely realized if the packages are encrypted, if a lock is added, this method is no longer able to detect malicious traffic. The flow-based approach does not face this problem as it looks only at packet headers, not their contents. A flow can be seen as the label that is attached to each packet. Listing various info such as the sender and destination, the weight of the packet, the size, etc. This analogy is not very accurate, but it gives you a general idea of what a flow is.

In order to do effective intrusion detection we need to know what the characteristics of malicious traffic are. Analyzing the traffic generated by dictionary attack tools allowed us to develop signatures. These signatures, as shown in Table 1, can be used to detect dictionary attacks from flow data. Two ranges are defined, the Packets Per Flow (PPF) and Bytes Per Flow (BPF).

During my Bachelor assignment much effort was put in developing a flow-based prototype IDS [1]. This prototype uses the signatures we have developed to detect dictionary attacks from given flow data. It detects attacks in three stages. First comes a preselection stage. Here, the data is filtered to generate a list of unique source and destination IP address tuples with at least one flow matching at least one signature. After this the detection stage starts. This is where the detection algorithm comes in. Every flow between the preselected IP address tuples is compared with the signatures. As the signatures define different ranges, there are also different modes of operation. Either only the PPF or only BPF or both the PPF and BPF at the same time are used for detection. If a tuple shows a consecutive number of flows higher than a given flow record threshold it is marked as being an attack. The last stage is the signature mat-

ching stage. This stage is necessary as there can be multiple signatures used in the detection stage. The basis of the signature matching algorithm finds its roots in the field of digital communication, namely the signal space concepts, where bits are mapped to a signal space to determine if a one or a zero was sent and received. Instead of using bits in a constellation diagram, we use the number of PPF and BPF on the axes of an imaginative constellation diagram, and the Pythagorean theorem for finding the signature that is closest to the analyzed traffic.

"We have become number one!"

We have become number one! That was rather difficult seeing that we were the only one around. But in all seriousness, accuracies of around 100% are achievable with the prototype, as shown in Figure 2. However we must acknowledge that there are false positives, normal traffic being marked as an attack. These false positives are mainly caused by (legitimate) automated traffic, such as Web crawlers. We realize these types of traffic can be of great importance



to Web site owners, as they often rely on search engine rankings for their income, for example. Further investigation of this traffic will therefore be part of our future work. In talks with Antagonist, we have learned that a system as presented in the paper may prove very useful. For example, it could be integrated with an automated system that blocks attackers based on detection results of our IDS. Requests from blocked IP addresses could be forwarded to a static landing page, from which one can choose to be unblocked. Since such behavior is not understood by attack tools, humans can easily be unblocked while automated attacks are mitigated.

Since this is only the first step towards intrusion detection against HTTPS, there remains a lot of work to be done. If you are interested in continuing were I left off, contact Rick Hofstede at the DACs chair.

[1] <https://github.com/ut-dacs/https-ids>

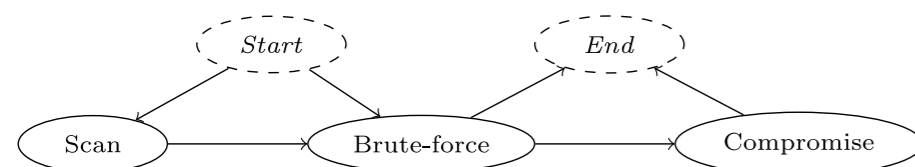

Figure 1: Dictionary attack phases.

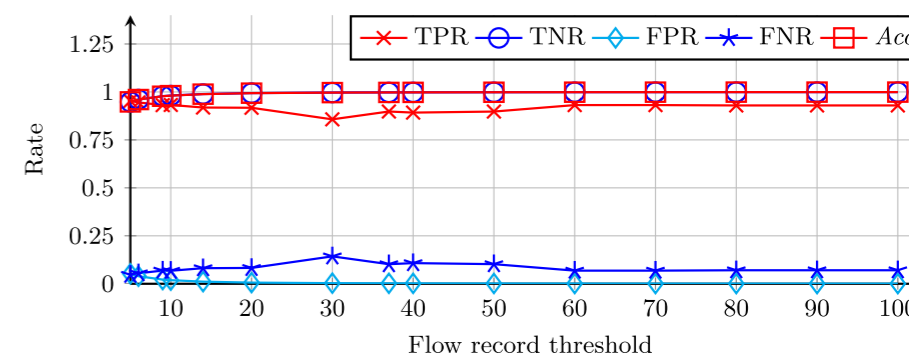

Figure 2: Detection accuracies for PPF under different flow record thresholds.

From hydrogen to electricity

Author: Ewoud Vissers

As most of you know by now, the Green Team Twente is a student team participating in the Shell Eco Marathon. This is a fuel efficiency race with several used fuels: Gasoline, diesel, battery electric, ethanol and hydrogen. The Green Team competes in the hydrogen category. The most important device in our car is the fuel cell. For the last three years, an off-the-shelf fuel cell system was used, a MES DEA 0.5, with a very low efficiency. This year we try to build our own fuel cell system, and hope to increase the efficiency.

Working of fuel cell

Fuel cells work using redox reactions. It has two sides: the anode and the cathode side. Hydrogen is brought in on the anode side, and oxygen on the cathode side. These two sides are split by a proton exchange membrane, which acts as the salt bridge in the redox reaction. The anode and cathode are electrically connected using an electrical circuit, which will carry the electrons.

The reactions happening inside a hydrogen fuel cell are:

At the anode side:

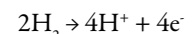

At the cathode side:

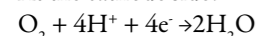

This makes the total reaction:

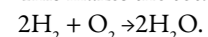

For these reactions to occur, the H^+ ions (protons) have to pass through the membrane, and electrons will have to pass through the electrical circuit. Given the hydrogen and oxygen supply are sufficient, this system has a VI curve similar to the one shown

in figure 1, please note that the X axis is in amperes per square centimeter. As you can see, the maximum voltage you can get out of it is one volt. This voltage is too low to use for most applications, so in many fuel cell systems there are many of these cells electrically connected in series. They are connected in such a way though that the chemical reagent for all cells are still supplied using the same ports.

In the VI curve it can be seen that the voltage of the cell is only high at very low current density. The amount of hydrogen used in the system is directly related to the current, because the current will dictate how many electrons are used, these will be split from the hydrogen. Because of this the efficiency of the chemical reaction is proportional to the voltage of the cell. The voltage losses in a fuel cell are caused by three factors:

- Activation losses – The reaction at the cathode is forced to go quicker than it would normally go, meaning it costs a little energy.
- Ohmic losses – losses due to the ohmic resistance of the proton exchange membrane



- Mass transport losses – losses at such high currents the concentrations of available reactants starts to become limited, because the individual reactions can not be performed quicker.

Efficiency of fuel cell

Since it is known that a fuel cell becomes more efficient at lower currents, the best solution would seem to be to exchange a high current for a high voltage, and making a very long stack. Unfortunately, there is a rule in the Shell Eco Marathon stating that no voltage in the car can be higher than 48 volts. This means we are limited in the amount of cells we can stack.

“We decided to buy a fuel cell stack from a German manufacturer.”

Another way to increase the stack's efficiency is to increase the surface area of the stack. Since the current in the VI curves is in am-

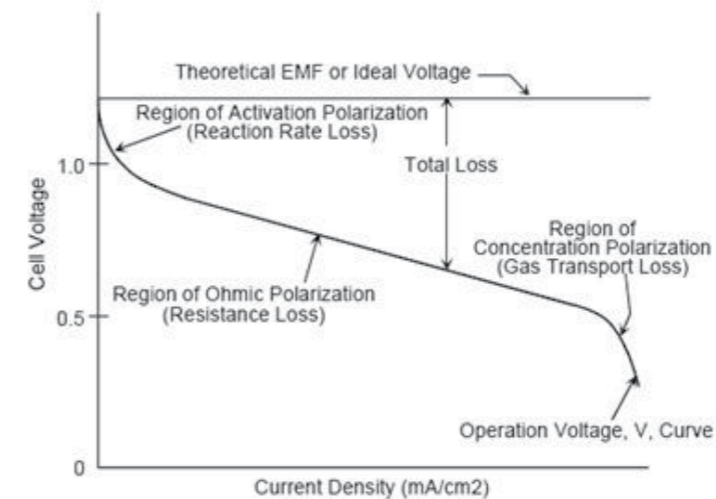

peres per square centimeter. In this way, the same currents can be pulled from the entire stack with a higher voltage.

After a long search, and some talks with other Eco Marathon teams we decided in the end to buy a fuel cell stack from a German manufacturer: Zentrum für BrennstoffzellenTechnik from Duisburg. It turned out we were not the only one with this idea. This year they deliver stacks for 6 other Eco Marathon teams as well. We chose for a stack with 50 cells, of 50 cm² each, compared to the current 22 cells of 63 cm² each. This means the new stack has half the cur-

rent density compared to the previous one, meaning it runs chemically more efficient.

Controlling of fuel cell

A fuel cell can not run by itself, it needs gas flows to work. If power is extracted from a fuel cell while there is no hydrogen on the anode side for example, reactions without hydrogen will occur to deliver the necessary power. Both the anode and the cathode have a catalyst layer made up of platinum particles supported by carbon. When the

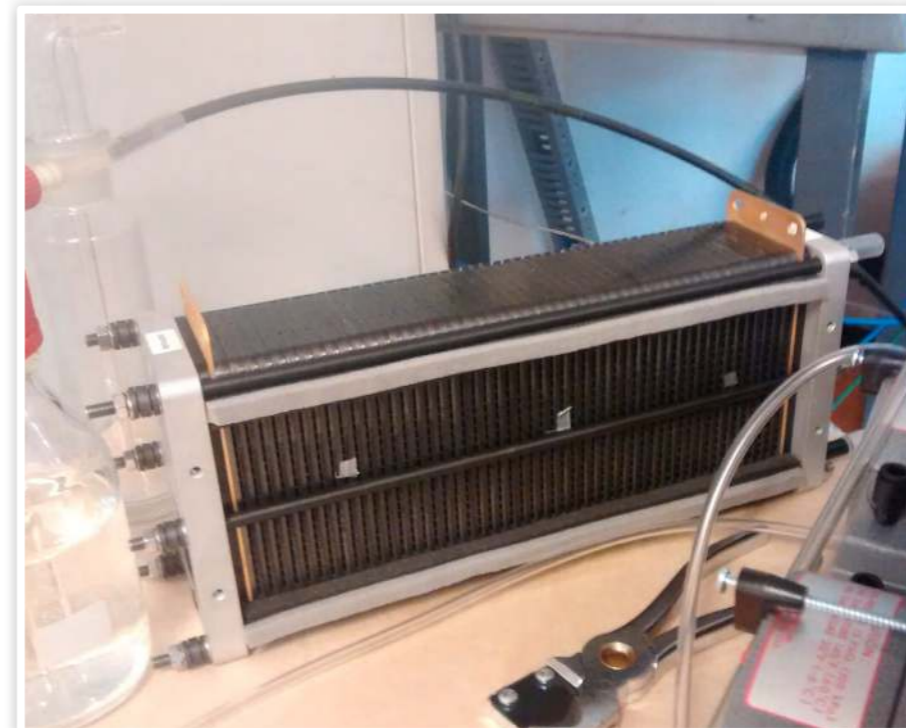

hydrogen is depleted, and some water is present (which there always is) the following reaction will occur:



This means the current through the circuit can be maintained without the hydrogen, but the carbon supports in the catalyst layer are irreversibly damaged. This means the area of your fuel cell where reactions can occur decreases, and its efficiency will decrease. Because of this, we need to make sure the supply of hydrogen will always be sufficient, and we have to find the most power efficient way of doing this.

Another thing that makes controlling a fuel cell difficult is purging. During operation, a lot of contaminants in the gasses will start sticking to the catalyst layer, effectively blocking off a part of the membrane. Nitrogen contamination in the hydrogen tank is a great problem, but liquid water forming at the catalysts is even worse. The only way to remove this water is to purge the fuel cell, meaning hydrogen will be blown straight through the cell, leaving it at the other end. Most hydrogen flowing through the cell while purging can not react, and will leave into the atmosphere immediately, causing a huge drop in efficiency. This is why we have to find the best points in time at which to purge, to lose the least amount of hydrogen to it.

In our old fuel cell, none of the parameters in controlling the cell were up to us. The cell was bought with controlling electronics, which made it an easy solution, but not optimal for our use case. This year, we will build all electronics around the fuel cell ourselves. This way, we know exactly what is happening, and we can find out where we lose the most amount of energy. This means it is easier to improve the fuel cell in the years to come.

Afterlife

From student to Hardware Electronics Engineer

During the study, you may probably ask yourself a couple of times: “What should I do when I’m finished?” Since this question doesn’t need to be answered in the early years of the study, the answer will come at the last moment of your master. However, it’s not the question: “What would I do?”; which is difficult to answer, but rather the question: “Where would I work as an Electrical Engineer?” The moment to finalize that answer is during the master thesis. In the coming paragraphs I will explain how I dealt with these questions, and what I have become today.

First, let me introduce myself. My name is Maurits Besselink, and, at the moment, I’m 27 years old. Many of you would not know me very well, due to the following facts: First, I didn’t spend many years in the University of Twente, because I had only followed the premaster and master Electrical Engineering at this university. Before that,

I had studied Electrical Engineering at the applied university in Arnhem (in Dutch, the so-called: HBO). Second, I didn’t initially become an active Scintilla member. However, when Scintilla started organizing the study tour to China, I joined, since I definitely didn’t want to miss this opportunity. While organizing the study tour, I was part

of the SPOCK 2 committee (like everyone else who participated) and I became familiar with the ins and outs of Scintilla.

“The number of valuable companies was not that high.”

After I came home from the study tour, which was accompanied by a holiday in South-East Asia in October 2012, I started my master thesis on the first Monday of November. Before the study tour, I had already finished all the master courses and I chose a master thesis assignment in the Integrated Circuit Design (ICD) group. This was something I definitely wanted to have arranged before starting the study tour, which required a lot of effort. A few months after starting my master thesis, I decided that it was the time to search for job opportunities. The annual company days at the University of Twente (in Dutch, the so-called: De Bedrijvendagen) was a good starting point for me. I went to the company market where different companies promoted their activities and I talked with people representing interesting companies. However, the

number of valuable companies was not that high in my opinion. From my childhood, I always had the affinity to design electronics. Thus, I was searching for a job, where I can work with electronics and where I can develop my skills as an Electrical Engineer. Besides that, I was searching for a job in the area of Achterhoek and Twente, because I had lived there my whole life and I like to stay there with my friends and family. For me, there were no concrete reasons to search for job opportunities outside that area. Therefore, I was searching for jobs in the topographical triangle: Arnhem – Apeldoorn – Enschede. All in all, when taking these criteria into account, only a handful of interesting companies remained.

When I searched for jobs at interesting companies online, I didn’t find many suitable vacancies. Only a few companies had posted their vacancies online. Hence, due to the contacts I made during the company days together with the contacts I made before, it allowed me to get in touch with a couple of companies and to talk with them about job opportunities on an informal level. I was not really nervous during those interviews, since I didn’t apply for an existing vacancy. Although I did apply for a job, I felt less pressure to fail in such a setting. The conversations were very useful, because I went to the companies, talked with them and observed how things happened on the work floor. It gave me a broader view how the varying companies that I was interested in operate. Most of these conversations had not resulted in a follow-up, since most of these companies didn’t require additional employees. However, the company USE System Engineering being located in Haaksbergen was one of the first companies that invited me for a second job interview. I became familiar with USE System Engineering during the organization of the study tour, where I joined the acquisition committee that was responsible for sponsoring this tour. Subsequently, I personally became in contact with USE during the symposium entitled: “Empowering the future” that was organized by Scintilla on the 15th of May, 2013. USE was present at the symposium with a stand and they attracted my attention with very interesting electronics. USE System Engineering belongs to the medium- and small-sized companies and they

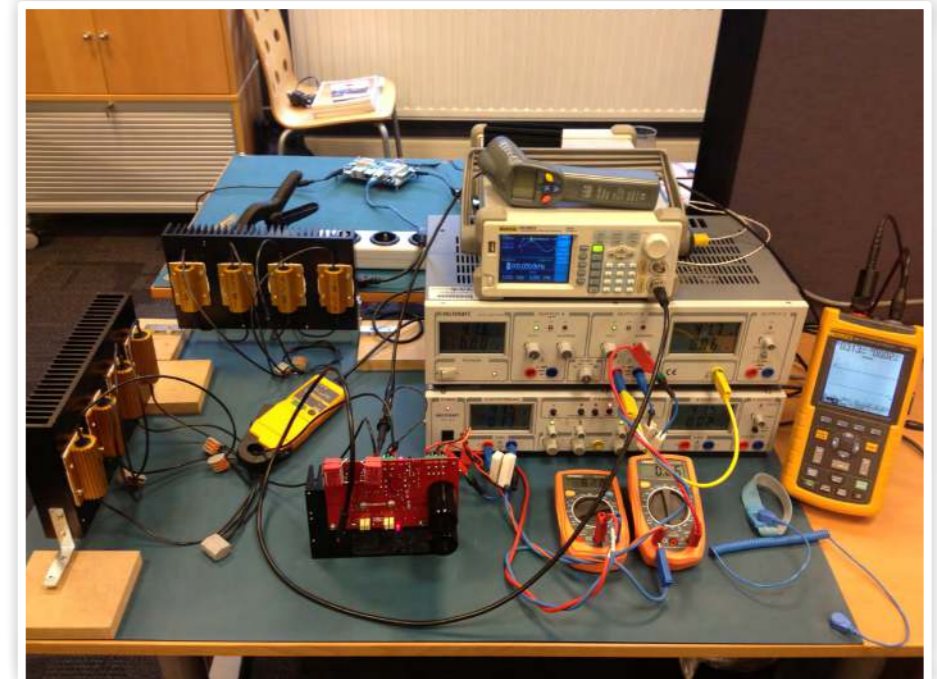

Test setup of the class-D power amplifier during my feasibility study

are specialized in the development of complete electronic systems. After conversations with larger companies as compared to USE, I decided that I wouldn’t necessarily like to work at a large company. Medium- and small-sized companies have also their advantages and opportunities, for example a more close contact with colleagues and the director, becoming familiarized with all the ins and outs of a company and having a larger variety of working activities.

“Medium- and small-sized companies have their advantages and opportunities.”

On a sunny day in early July of 2013, I became Master of Science after defending my master thesis. One day after the defense, I went to USE for the second job interview. During that interview, I became convinced that I want to design electronics at a small company. The projects that were presented by USE encouraged me to cooperate with the team to develop complex electronic systems. Within a couple of days after the second interview USE System Engineering

offered me an annualized contract as “Application Engineer”. In fact, it involved a job position as a hardware electronics engineer. The term “Application” refers to a multi-application view which an engineer needs. I didn’t require much time to take the decision and I readily chose to work for USE System Engineering.

After a great holiday of 8 weeks, I started my life as a working citizen with a real job on September first. The nice thing about being a working citizen is that you receive a decent salary (finally after years of studying). From the first day at USE, I joined the development team that worked together on impressive Contactless Energy and Data Distribution technology, in short CEDD. It is a technology being developed by USE, where devices without being physically in contact with a cable (contactless) can be provided by power and communication simultaneously. In particular, the CEDD technology is applicable in harsh environments, like airfields, offshore platforms and tunnels. Those devices are being placed on top of one cable that is controlled by a centralized base station. The base station contains, among several other components, power amplifiers that provides correct voltages and currents to the cable. My first assignment at USE involved a feasibility study of a class-D am-



Me working during system verification

plifier topology for those amplifiers inside the base station. I immediately became an engineer who worked on this great technology. It was a very exciting and challenging task for me. In the first month, I investigated whether a class-D amplifier integrated circuit (IC) can be used in CEDD. It concerned a 420W class-D audio amplifier IC from NXP with a maximum efficiency of 93%. After doing some calculations and simulations, I needed to test the IC in

“This IC is not suitable for CEDD!”

practice. Thus, I ordered a readymade test board with the dedicated IC from China, to save time building a complete printed circuit board (PCB). When the test board arrived, I first needed to make some modifications and then I started the real work: the verification! After I performed a substantial number of measurements and blowing up the IC twice (and the IC expected to be unbreakable because of 8 kinds of protection mechanisms), I formalized an end conclusion. This IC is not suitable for CEDD!

After the feasibility study, there was a lot of work to be done to bring CEDD techno-

logy to real products. The first system that was designed, confirmed the proof of this technology, but it was not yet suitable to be sold. The first CEDD base station was really large and it contained several expensive components from third parties. The goal of the development team became to bring down the size and costs of the base station and make it suitable for large-scale production. To achieve that goal, three PCBs needed to be developed by the hardware engineers including myself. My hardware colleagues were responsible for most of the designs, but I designed particular electronic circuits as well. Subsequently, my job was to join all the designs together and create the electronic schematics of the PCB. After the review of the schematics, I started with the layout of the PCB. That was something which required much precision. It's not only about the connection between two components, but there are many other aspects to be considered, such as the width and length of traces (due to currents and Electromagnetic Interference (EMI) respectively), the position of the components (due to placement during production), grounding (due to return path of currents) and many more. The broad perspective that was needed to perform this task was something I liked about this work. After ordering and receiving the PCB, a third party assem-

bled it and subsequently it was my task to verify the PCB. That is an important step during the development, because it proves the correctness of the design.

The process from design to the verification of the PCB was performed three times successively, since three PCBs had to be designed. After that, we as development team had the verified building blocks of the new base station, but that didn't mean we were finished at that particular moment. The three PCBs together with power supplies from a third party were built into a mechanical case, which was also designed by USE. Subsequently, it was my job to verify and to characterize the complete base station, which takes a lot of time. At the moment (November 2014), I'm still working on

“All in all, there is plenty of exciting work left for me.”

the system verification. When I finish this task, we will start the certification process which is needed before we can produce the products on a large scale. All in all, there is plenty of exciting work left for me.

As part of the development team of CEDD, my work is challenging and I hope to proceed working on the CEDD technology for a long time. CEDD is such a complex system, that everyone with interest in analog circuits, power electronics, high-speed communication, interfacing with CPUs and FPGAs and more will work on it with pleasure. The market has announced a lot of great words about the CEDD technology and we expect that the CEDD technology will be implemented for multiple applications. Therefore, to cope with that demand, we need to develop CEDD products being suitable for different applications. Because of that I want to do my best in the coming period at USE System Engineering to make that possible!



Test setup of the CEDD base station hardware

Design of a mini-anechoic chamber

Author: Roelof Grootjans

In the field of telecommunication engineering, it is often important to conduct accurate measurements on antennas or wireless links to evaluate their performance. If the measurements are performed in a normal lab, reflections of the electromagnetic waves from the walls and objects will spoil the results. Hence to conduct these measurements, there is a need for a room which does not reflect these electromagnetic waves. Such a room is called an anechoic chamber (literally meaning that it does not produce echoes). This article will give some details about the construction of a mini-anechoic chamber for the telecommunication engineering research group.

Background information

To understand how an anechoic chamber works, it is first necessary to see how radio waves react when they encounter surfaces. Firstly, it is assumed that all waves used in this article are uniform plane waves in the far field of an antenna. The cross section of the anechoic chamber is shown in Figure 1. There are in this case two radio waves, A and B, respectively generated from the inside and the outside of the chamber. The inside of the chamber is lined with absorbing material. This material is specifically designed to absorb microwaves. If the energy from the transmitting antenna is not absorbed before it reaches the wall, it will reflect off it and reach the receiving antenna together

with the transmitted signal. This means that at some frequencies the electric field at the receiving antenna (sometimes the same as transmitting antenna) can either interfere constructively or destructively. The outside of the chamber is made from metal to shield the external electric field from interferers such as cell phones and Wi-Fi networks.

To understand the principles and electro-dynamics of shielding please refer to the book of Clayton Paul[1]. Basically for a good shield against electric fields, choose a material that has a good conductivity and make it thicker than its skin depth. The outer shell of the chamber is a good conductor (steel in

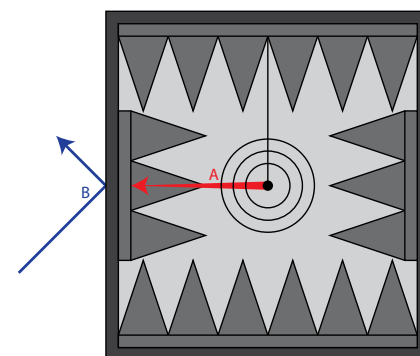

Figure 1: Cross section of an anechoic chamber (not to scale), where A depicts a radio wave generated on the inside while B depicts a radio wave generated on the outside of the chamber.

this case) which is effectively a short for radio waves resulting in almost 100% reflection. Important for shielding is that no leaks are present because they will function as slot antennas that radiate the external fields to the inside of the chamber. As mentioned earlier, the inside of the chamber is lined with microwave absorbing material. This material is lossy at the frequencies of interest (in this chamber 1GHz to 10GHz). It has about the same wave impedance of air, which causes the radio waves to dissipate in the material. The absorbers are also taped so the frequency range is wider. Also waves can dissipate by bouncing between the absorbers.



Figure 2: Close up of the flange with gaskets mounted.

Design

Basic design of the chamber is relatively easy. It consists of a large shielded box with inner dimensions of 950mm x 900mm x 1950mm. The box is constructed by a company that makes custom air ducts. The main part is the duct itself with two flanges at the ends. Two hatches are mounted over the flanges and are bolted down tightly. A close-up of the flange is shown in Figure 2. Gaskets are placed around the edges of the flange to make good electrical contact between the hatch and the chamber.

The absorber pyramids (DMAS MT25[2]) are mounted on mats of the same material (carbon loaded polystyrene), which makes them easy to detach. To install them the mats were cut to size and stuck to the cham-

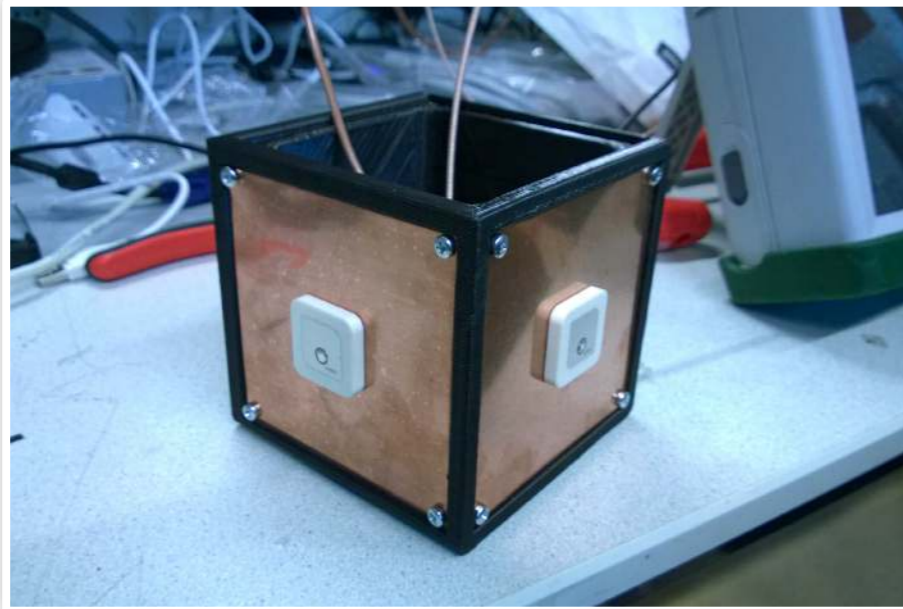

Figure 4: A small satellite model with mounted antennas.

ber using heavy duty double sided sticky tape. When all mats are in place, the pyramids can be inserted to complete the chamber. The inside of the chamber without the small satellites is shown in Figure 3. This application required two small satellites in free space. These satellites were mounted on Plexiglas rods with cables fed through.

The angle of the satellites is controlled by a stepper motor. The satellites are made from a 3D printed hull. Antennas are mounted

on copper ground planes that fit in the satellite. In the final setup a radio link will be tested around 2.45GHz, so for testing this frequency will also be used. The antennas used here are patch antennas[3] with circular polarization and a center frequency of 2.45GHz. Each satellite contains two antennas mounted at a right angle from each other. Figure 4 shows one of the satellites.

Results

The functionality of the chamber was verified quickly using a qualitative measurement. This measurement setup is shown in Figure 5. A spectrum analyser with tracking generator is used to measure the transmission from one satellite to the other in a frequency band of 100MHz around the 2.45GHz. In each measurement one satellite stays fixed while the other satellite is rotated with increments of 90 degrees. Every time the satellite is rotated, the transmission is measured again. This measurement is conducted with a fixed distance between the satellites (enough to keep the antennas in each others far field). Also for a comparison, the measurement is conducted in a normal lab environment (so with a lot of reflections) with the same distance and angles. The measurements results in the normal lab space are shown in Figure 6, the results of the anechoic chamber are shown in Figure

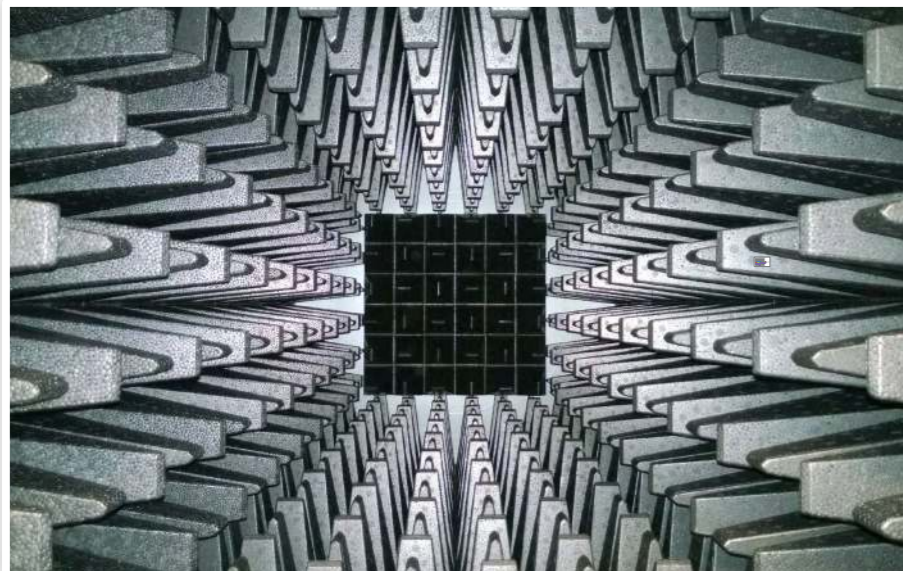

Figure 3: The inside of the chamber where the walls are lined with microwave absorbing material.

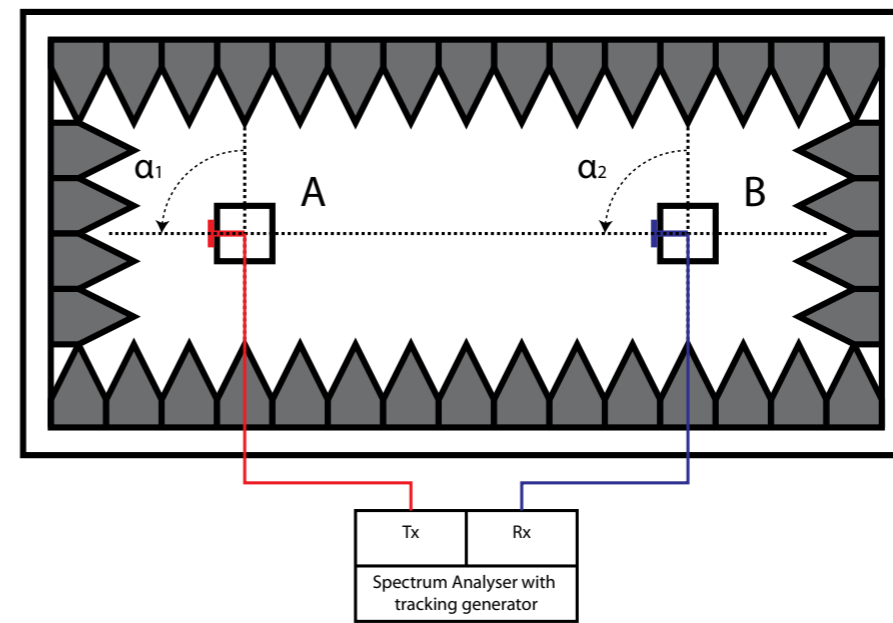

Figure 5: Measurement setup used for a quick qualitative measurement.

re 7. From the results one can see that there are a lot of fading dips in the measurement in the reverberant room which is caused by radio waves interfering with reflections. When the same measurements are performed in the anechoic chamber, these fading dips are absent because the radio waves are reflected of the walls.

Conclusion

An anechoic chamber with rotatable satellites is realized to be used for the testing of wireless links between satellites. The environment is suitable for these test because the inaccuracies caused by reflections of the objects and the room itself are eliminated (which emulates a free space environment). A small qualitative test showed that fading dips are indeed absent.

For questions you can reach me at: roelofg@scintilla.utwente.nl

References

- [1] C.R. Paul, "Shielding", in Introduction to Electromagnetic compatibility, 2nd ed., New Jersey, John Wiley & Sons, 2006.
- [2] Dutch Microwave Absorber Solutions bv., Product overview Microwave absorbers (MT-series)[Online], Available: <http://dmas.eu/wp-content/uploads/2013/12/Product-overview-MT-absorbersv3.0.pdf>
- [3] Taoglas antenna solutions, 2450MHz Patch Antenna, [Online], Available: <http://www.taoglas.com/antennas/Wi-Fi-Zigbee-Public-Safety/Internal-2.4GHz-Passive-Patch-Antennas/>

Transmission anechoic chamber

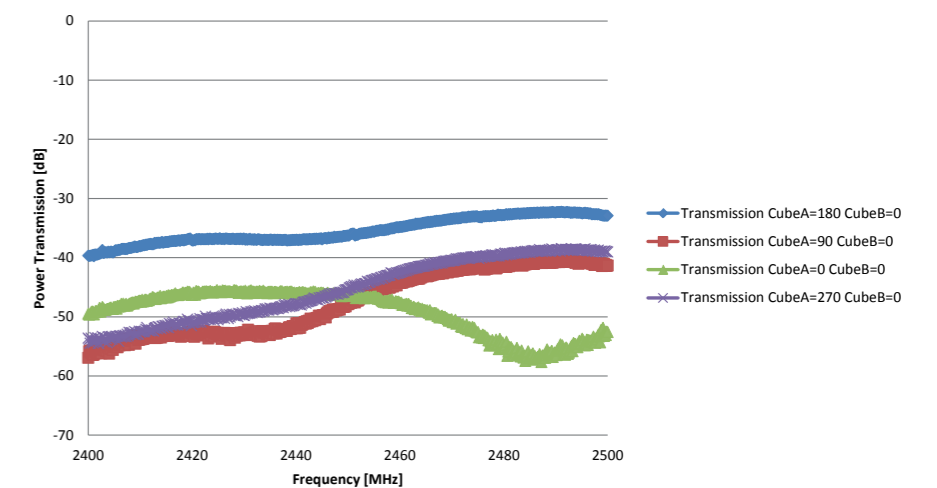

Figure 6: Transmission from satellite A to B in a reverberant room for different angles of satellite A

Transmission reverberant room

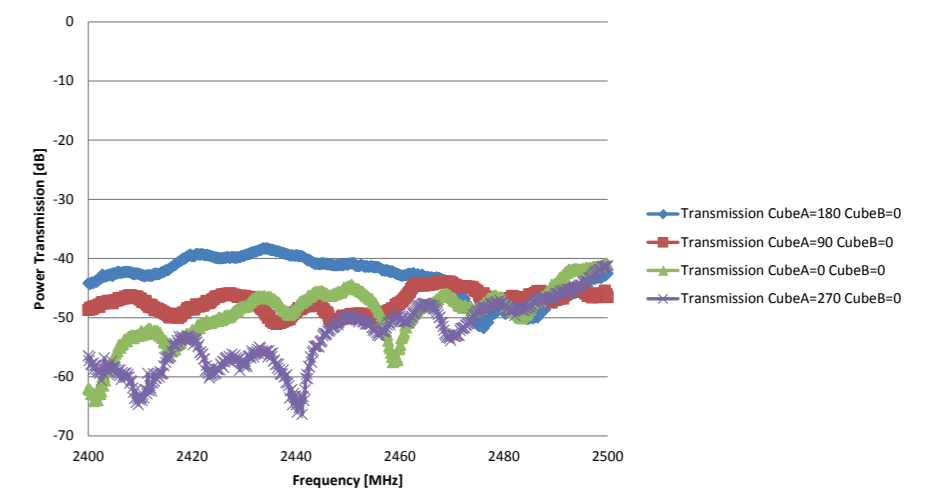

Figure 7: Transmission from satellite A to B in the anechoic chamber for different angles of satellite A

Amazed by the lights

Internship in Hong Kong

As a child, large cities have always impressed me. When driving back from my grandparents, my dad sometimes drove us by Rotterdam, to make us happy. I always looked out of the window and was amazed by all the lights coming from these big cities. Then, I had never foreseen that there would be a time when Rotterdam would seem not that big and amazing anymore and that I would live in a city with its own lightshow, Hong Kong.

In the spring of 2014, I went to Hong Kong to do my internship at the Hong Kong Polytechnic University. With a population of over seven million people, Hong Kong is one of the most densely populated areas in the world. It formerly was a British colony, influences of which are still visible. It is officially a part of China, but has its own laws and government. Because of the good economic environment, a lot of foreigners come to Hong Kong for work and internships. Luckily for me, almost everyone could speak English.

I worked as a research assistant at the Department of Computing in the field of Biometrics. Biometrics refers to the recognition of individuals by their characteristics or traits. Fingerprints, faces and irises are traditional examples of biometric modalities. A relatively new modality in biometrics are finger-vein patterns, which can be captured using infrared light. There are only a few finger-vein image databases, which are all small of size. As a result, finger-vein recognition algorithms cannot be tested thoroughly. To overcome this problem, my supervisor gave me the task to perform finger-vein synthesis.

Biometric syntheses make use of a computer to generate biometric data. I had to generate a database of fake finger-vein images, with the same characteristics as real finger-vein images. In order to try to mimic real finger-vein images as closely as possible, an anatomically based method was used. A vein pattern was generated, after which the effects of capturing were added. An overview of the model is shown in figure 1. The basis for

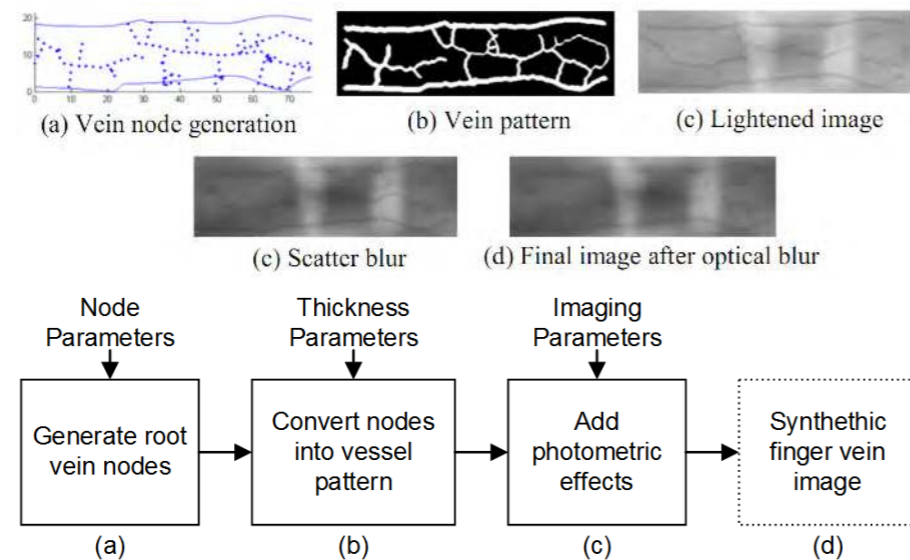

Figure 1: Biometric synthesis of finger-veins

Author: Fieke Hillerström



the vein patterns are root vein nodes. These were generated, using a kind of 'grow' model (a). The root vein nodes were converted into a thin vessel pattern, using dilation and thinning. The thickness for every vein node was calculated and added to the pattern, after which the vein pattern was obtained (b). The vein pattern was used as basis for the final synthetic finger-vein image, for which the photometric effects had to be added. These photometric effects include the varying light penetration through different parts of a finger, scatter blur, and optical blur. When the images were compared with real finger-vein images (see figure 2), they had acquired a similar appearance.

During my internship, I learned a lot about Hong Kong, and Asian culture in general. It was a really new experience for me to live in such a densely populated and busy city. Small shops and markets are all over the streets. The city wakes up relatively late, but also goes to sleep later. Most shops are open from 10:00 to 23:00. The people of Hong Kong tend to work hard, and working on Saturdays is not uncommon in some sectors. Most of the people go out for dinner, because it saves time and the kitchens, as well as the apartments in general, are small. Eating out is also a social event. People celebrate their birthday, for example, by going out for dinner. There is simply no space for a party at home. My own birthday was during my time in Hong Kong. Together with my colleagues, we went out for a special lunch. From my supervisor I received a typical Chinese gift; red envelopes with a small amount of money. They see receiving a red envelop for your birthday and other special days as a symbol for luck.

Preparing for an internship in Hong Kong takes some time, but is not that difficult. One can go to Hong Kong as a visitor without a visa for 90 days. For a paid internship,



however, a visa is required. The visa was arranged by the university. It takes some time and paperwork, but overall is not that hard to get. My visa was ready just in time, and I had to go to Macau to activate it, because I first entered Hong Kong as a visitor. Macau is only one hour by ferry, so that was not a problem. Finding an affordable room, however, was somewhat more difficult. Rooms in Hong Kong are small and expensive. There are some websites where you can search for rooms and one of my colleagues helped me with finding one. You can look whether the university can provide accommodation, but in my case it was not possible. The transportation in Hong Kong is good and uses a better version of the 'OV-chipkaart', the Octopus card. You can get almost everywhere by MTR and otherwise there are a lot of buses, which give you a nice view of the city when sitting top level. In the spring it can rain a lot in Hong Kong and the temperature rises. Most of the people use an umbrella, either against the rain or against the sun.

Don't let the crowdedness deter you, Hong Kong is an interesting city to go to. It has an amazing skyline and the view from 'The Peak' is even better. The government in-

vests in beautiful parks, where you can relax. The people are very nice and willing to help. There is a large group of young interns and expats, that organize activities, and go out in the evenings and weekends. Hong Kong consists of a lot of nature and islands and people love to hike there. I went on several hikes and other activities with this internship group. Every Wednesday there are horse races, where the locals like to bet. The influences of the Chinese culture are visible in the temples, festivities, delicious food and out on the street. There are a lot of cultural activities to see, during the Chinese related public holidays and on the outlying islands. Hong Kong is a really interesting city to have lived in and to connect with the Asian culture. Like some once told me: 'Hong Kong is Western from the outside, but Chinese from the inside.'

If you want to know more about my assignment or about Hong Kong, feel free to contact me.

Reference:
[1] Ajay Kumar and Yingbo Zhou. Human identification using finger images. Image Processing, IEEE Transactions on, 21(4):2228-2244, 2012.

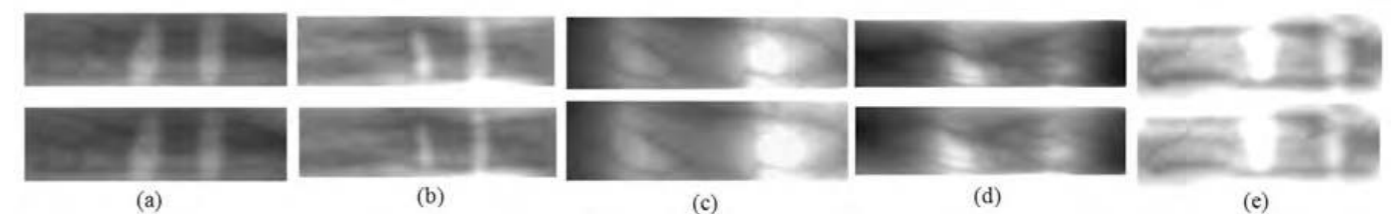

Figure 2: Sample images from the synthesized finger-vein database in (a), (b) and (c). The images in (c) & (d) are real images from real finger-vein database in [1].

Homey: Talk to your home

Author: Peter Oosteweche

Most of you have heard about Homey. This new home automation device can control your home by having you speak to it. The device communicates with appliances by means of 7 different radio+ infra-red technologies. It was successfully funded on Kickstarter in June 2014 with more than €200,000, twice the intended target. It was my job to design the hardware, as well as develop the PCB.

Before the summer, I was looking for internships which started in September, and had a few companies in mind in the Enschede region. Upon seeing the Homey Kickstarter page I was sorry for the poor soul which had to make the hardware to provide all the functions promised in the Kickstarter campaign. Shortly after that, Emile, the creative mind behind Homey, asked me for an Internship. Turns out I was that poor soul. Luckily, I was not alone, and had the help of another awesome Electrical Engineer with a lot of practical experience: Danny Bokma.

industrial design, interface design, and marketing. There are a lot of advantages doing your internship at a start-up. The biggest, in my eyes, is the opportunity to get an inside look at the business-side implications of designing a consumer product. Think about profit margins, selling your idea to investors, how to even produce 1000 units within a reasonable time span and keep costs low. All things you would normally not get insight into. There is also a downside, however. Since the Electrical Engineering facilities are virtually non-existent, Danny and I, in



take company outings to Ikea, ordered new computer monitors and office supplies. I even installed the kitchen together with the water and drain facilities together with Danny. Some welcome variety in the first few weeks, compared to the mentally straining task of system level design.

My assignment

This brings me to my exact assignment: the hardware design of Homey. As I said before, a lot of promises had been made on Kickstarter about its functionality. Now, it was up to me and Danny to find all the technology to make this happen. From these promises, we had to make a list of requirements, and represent them with possible components. Just to give you a taste of the daunting task we had to face: Homey sup-



Figure 1: PCB Design

The company

The company behind Homey is Athom. Founded in May of this year by two Creative Technology students, they truly are a start-up. They want to position Homey at the centre of the home automation market, with peripheral devices circling around them like electrons around an atom. The business is located in Spinnerij Oosterveld in Twekkelerveld, so it really is close to home. I have a morning commute of a whopping 5 minutes. It's even closer than the University of Twente! We have a team of 6 people spanning the whole scope of the design, from software and hardware, to

the meantime, moved half of our home to the office. The fact that they were a start-up became apparent when I started my internship. Athom just moved into the new office which is shared with another start-up so the office was quite empty. In addition to my Electrical Engineering tasks, I had to

“There are a lot of advantages doing your internship at a start-up.”

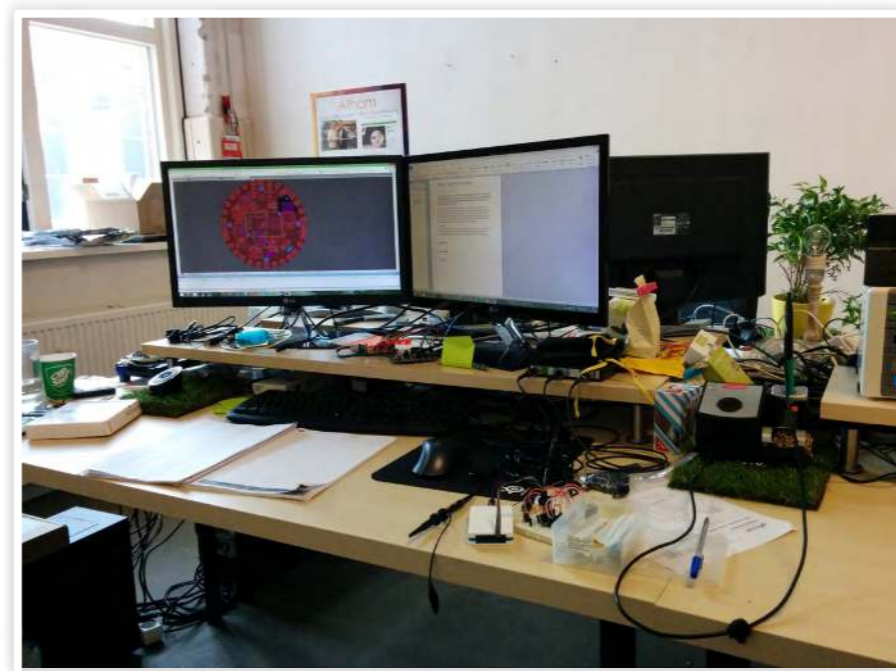

shed the PCB design of the first prototype and it is currently being manufactured. See figure 1 for the results. The integration into the final case can be found in figure 2. Looks really nice if I say so myself. We cannot wait for the first prototype to arrive.

The future

My internship will last until Christmas, and after that, I'm going to focus on graduating. However, there is still a lot of work to be done. Especially in the field of embedded software programming, certification, Linux integration, and testing. If you are interested, you can contact Emile Nijssen.

In the meantime, we have also integrated a lot of Homey in our office already. It's always nice to have your office greet you in the morning, and turn on the lights automatically.

I am having a great time, and honestly, who can say that they helped create a consumer product with the potential to sell thousands!

Halfway through

At the time of writing I'm already halfway through my Internship. Time flies when you're having fun! In the last week we fini-

ports Wi-Fi, Bluetooth 4.0, ZigBee, NFC, Z-Wave, 433/868 MHz, nRF24l01+, infra-red, microphones, a DSP, and a computing core. For each of these technologies, we had to find alternatives, research feasibility, and connect them all together.

After some setbacks caused by incorrect manufacturer information and lacking datasheets, we finished the first stage roughly at the beginning of October.

Once the exact components were known, we were ready for the next step in the design process: creating symbols, footprints, and schematics. From that point, it is possible to create a PCB, which is quite important, what with all the wireless transceivers and connections present. Going to market also has a lot of implications, and some things have to be taken into account: cost, power usage, EMC immunity, radiated EMC, CE/FCC approval, antenna placement, producability, factory programming, recovery mode, etc. That's not even all of it, quite an involved process indeed!

Another cool thing, is that we, as hardware engineers, are very closely involved in the case design. Everything has to fit together, after all, and as a direct result I also learned a lot about designing and producing cases by means of injection molding.

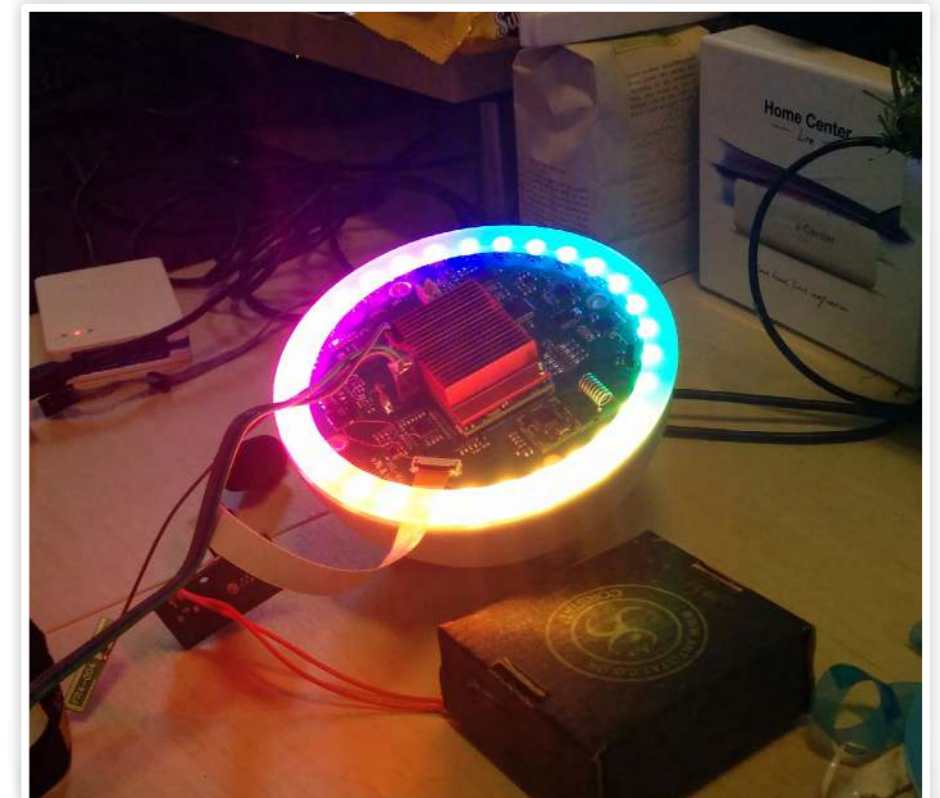

Figure 2: Integrating the PCB design into the final case.

Junction

Jeroen Klein Essink

is starting his first year of Electrical Engineering. However, this isn't his first time starting the program, as he has previously spent 3 years studying the subject in the previous educational model. We decided to talk to him in a bit more detail about how his life has changed, and inquire more about the major changes since he last attended.

What is your favorite color, and why?

PMS 185. Well, some things, you can solve with science. Others, however, must come from the heart. Transistors, for instance, as well as PMS 185 relate to the latter.

You are returning to this study. How many years did you study before, and what stopped you?

I followed the Bachelor Program for 3 years.

What stopped me was primarily the lack of results. Since I didn't do well enough, I decided to take a break, which lasted 6 years. During the break, I tried following the HBO program part-time in addition to working 32 hours per week. I was primarily working on the testing and service of power electronics. However, I was generally too tired from working to get enough work done in the study. That, with the combined lack of motivation, meant that I didn't really get far in the program.



Author: Maksym Aleksandrovych

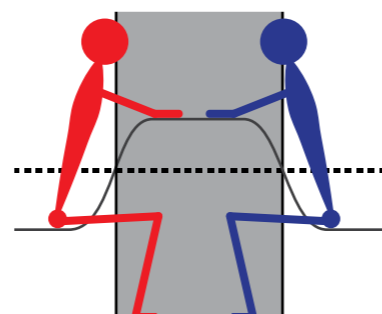

Do you feel that the part time work you did in a related field, in addition to the years of study, helped you out, upon returning to Electrical Engineering?

Of course it did help. Since the majority of the work was practical, it really helped, especially since the current educational model focuses a lot more on practical, rather than theoretical assignments. While working, I had also worked on PCB designs, and that pretty directly correlates to the content that we'll study in the upcoming years. Overall, you do develop intuition, which is pretty important in the earlier stages of the program.

Speaking of the current Educational Model, what do you feel are the main changes, and what would you say are some negative and positive aspects of each?

In the new educational model, there are far more tests during the semester itself, which force you to keep up with the content you're meant to learn. This way, you don't just start studying for the final exam a week in advance, and realize you know absolutely nothing. Some people might complain that the tests could be reduced to one every 2 weeks, however, I feel that personally for



Jeroen Klein Essink

Age	26
Study year	First
Birth place	Amsterdam
Favorite Color	PMS185
Favorite Drink	Grolsch

me, at least, having a test once a week is entirely manageable once you get used to it, and helps you "stay in the loop", so to speak, much more easily.

A pretty big negative aspect about it, however, is the way that EC's are now credited. Previously, you would receive separate EC's for each course within a module that you

"Overall, you do develop intuition, which is pretty important in the earlier stages of the program."

took. This way, if you only failed a single course, you would only have to redo that specific course. Now, it is very much an "all or nothing" system, which I feel encourages more the behavior of "just passing", as you are more likely to pass everything, rather than actually encouraging students to get

higher grades.

All in all, I feel the system should be combined to include the many small tests, which encourage better learning habits, as well as the separate EC's. Because, it is far too easy to fail a single test due to a sickness or injury, and if that results in having to redo a whole 3 months of work, that is a system that needs improving.

Focusing a bit away from the studies, how do you generally spend your time outside of them? Do you have hobbies, are you part of a study association, etc.

Well, as I assume most people in our study do, I occasionally play some video game to wind down after studying. In the summer, I like riding my bicycle. And in the winter, I tend to go running.

I also used to play in a chess club, but unfortunately, it closed last summer, so now I generally play it online.

Currently, I am not part of any student

associations (at least actively). When I studied previously, I was a lot more active within Scintilla. Since I was a new student, at the time, it was a good way to make new friends. This time around, however, I wanted to focus more on my studies, and as a result, I feel that, as fun as they can be, it better to first get into the swing of things as far as the study is concerned, before considering being more active within an association.

What is the biggest change for you since the last time you did this program?

Since last following this study, I had been diagnosed with Asperger's Syndrome, and as a result of which, in addition to extra time during tests, I also have a lot more support. I feel that knowing this last time would've meant that I would have gotten much better results. But now, due to the help, I also have someone to give me "a kick in the backside" when I need it.

Ultimate Transfer

Author: Dieuwertje ten Berg

Do you know the feeling you get when you realize that you learned something? I don't mean during lectures, but in real life situations. Those moments when you realize that you react different to a situation than before. That moment when you think "a year ago, I could not have done this". And then a split second later the realization that you have learned something. It is the realization that you have grown as a person.

For me, moments like that are real revelations. I love those moments. It is the sign that I've actually accomplished something, that what I've done wasn't a complete waste of time. That is quite strange when you think about it. After getting my bachelor degree, I could feel like I have accomplished something. But for some reason it all seems normal. I wonder; am I the only person who feels like that?

The moments I realize that I have learned something are more about personal achievements than academics, I guess. It is more about the way I react to situations or handle things. It is not so much about knowledge I have gained. Maybe it is the ultimate form of transfer, implementing what you have learned and being aware of your new behavior.

"It is the sign that I've actually accomplished something, that what I've done wasn't a complete waste of time."

But then again, why is our educational system not more focused on the realization that you have gained experience and thus, knowledge? Because, those moments when I recognize that my own behavior has changed, are moments of recognizing new knowledge. Those moments are crazy mo-

tivating for me. They really add meaning to my actions and choices. It is weird that we don't focus more on these moments. In the process of learning and gaining knowledge, we completely forget the process of learning. The process is necessary to learn, something you do, but never the focus.

How often do you think about your own learning process? I guess not that often. When you do think about it, it is probably about how well you study is going, or how far you are behind on a subject. How often do you think about what you have learned? Do you realize that you are doing things now differently than a few years ago, or perhaps just a few weeks ago?

I never really think about it, but I think we should think about it. It is okay to realize that you have learned and that you have grown. It is motivating, for me at least. Maybe the process of learning is often too gradually to notice. Maybe all the experiences follow up each other so nicely, that growth isn't noticed any more. Maybe that I notice it now after my board year, is because it was a year in which experiences didn't went smoothly and gradually.

But you can't always throw your students off the deep end. So how can you help people realize that they have learned something? And not with testing, when you put a mark on something to show that someone knows something. That has so little meaning, and so little of knowledge learned in a classical situation is actually transferred to the real world. How can you make people feel that they have learned something?



The beauty of this question is that there isn't one answer or actually really an answer at all. There are some many things that could be tried. Some might work for some people, others might not work. These kinds of questions make me realize why I choose my study and why I like it so much.

"It is okay to realize that you have learned and that you have grown."

Last, but not least, I would like to invite you to think about your own learning process. Are you doing things differently now, that you did before? Do you ever realize that you have learned? Do you ever notice that you have learned? How does it make you feel?

Lots of educational love,
Dieuwertje

Puuzle

Author: Truusje

Logic puuzle

The board of Scintilla wants to make high-pass filters (according to figure 1) that will only let frequencies higher than 1 kHz pass. Each of them picks one resistor (100Ω, 200Ω, 400Ω, 800Ω, 1600Ω) and one capacitor (100nF, 150 nF, 400 nF, 500 nF, 2000 nF). After building their filters according to figure 1, it appears that no one has used the same resistors or capacitors.

If you want to have a chance to win a pie, please send your solution to me via e-mail (truusje@scintilla.utwente.nl) or deposit it with your name in the mailbox of the Vonk in the SK.

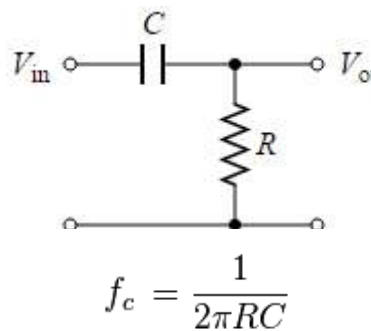
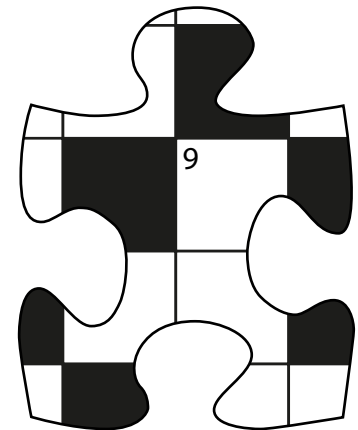

figure 1: Circuit and formula filter



We know the following:

- Mickey and Jippe did not pick the 150 nF capacitor
- The person that picked the 400Ω resistor picked either the 2000 nF or the 400 nF.
- The resistance of the resistor picked by Bob is twice as high as the resistance used by the person that picked the 2000 nF.
- Mickey chose either the 150 nF or the 1600Ω (so not both).
- Roel did not pick the lowest resistance.
- Joep's resistance is twice as high as Jippe's resistance.
- The person who used the 1600Ω picked the 100 nF as well.
- The person with the 400Ω resistor did not pick the 2000 nF.

Who succeeded in building a correct filter?

		Capacitors					Resistors				
		100 nF	150 nF	400 nF	500 nF	2000 nF	100 Ω	200 Ω	400 Ω	800 Ω	1600 Ω
Board members	Mickey										
	Joep										
	Tobias										
	Jippe										
	Roel										
Resistors	100 Ω										
	200 Ω										
	400 Ω										
	800 Ω										
	1600 Ω										



MAKING THE CONNECTIONS THAT COUNT

As a \$13B global leader in connectivity, we're part of some of today's most exciting innovations. Because at TE Connectivity, we build the connectors that engineers rely on to transport power and data, helping them solve today's biggest connectivity challenges in new and creative ways. And together, we're working toward a future of greener vehicles, faster networks, connected factories, and smarter devices—because every connection counts.

Connect with us at everyconnectioncounts.com

2013 All Rights Reserved

NYSE: TEL

EVERY CONNECTION COUNTS

